



EF300 pH RX

INSTRUCTION MANUAL

CE

WARNINGS



This manual is dedicated to the technical personnel responsible of the installation, management and maintenance of the plants. The manufacturer assumes no responsibility for damages or malfunctions occurring after intervention by non-authorized personnel, or not compliant with the prescribed instructions.



Before performing any maintenance or repair action, ensure that the system is electrically and hydraulically insulated.



Dispose of waste material and consumables accordingly with local regulations.

GENERAL SAFETY TIPS



WARNING! Before performing any operation on the pump, unplug the pump and discharge the liquid from the pump head and tubes. **Never operate on working pump!**



During maintenance and repair of parts that normally become in contact with chemicals, always wear all prescribed personal protections (gloves, clothes, glasses, etc.). The pump has to be handled by qualified personnel only. Always use original spare parts for maintenance.

Failure to follow instructions can cause damage to the equipment and, in extreme cases, to people.

How to ship the instrument

To send back the device for repairing or calibration purposes, proceed as follows:

- Fill the module “REPAIR REQUEST AND DECONTAMINATION DECLARATION” supplied with this manual, and include it in the transport documentation.
- Clean the device properly, to eliminate any hazardous residuals.

The manufacturer can modify the instrument or the technical manual without advanced notice.

Warranty

All STEIEL products are warranted for a period of 12 months from the delivery date.

Warranty is not valid if all instructions of installation, maintenance and use, are not strictly followed by the user.

Local regulations and applicable standards have also to be followed.

In particular, the warranties regarding the operational safety and reliability of dosing pumps will be recognized only if the following conditions are fulfilled:

- The installation, wiring, adjustment, maintenance and repairs performed only by qualified personnel
- The dosing pump was used according to instructions provided in this manual
- Only original spare parts have been used for repairs

TABLE OF CONTENTS

PACKING LIST	5
INTRODUCTION	5
INSTALLATION	5
TECHNICAL DATA	6
FUNCTIONAL DESCRIPTION OF THE SYSTEM	7
HYDRAULIC CONNECTIONS	9
<i>Suction Line</i>	9
<i>Bleed Line</i>	9
<i>Injection Line</i>	10
PRIMING	10
ELECTRICAL CONNECTIONS.....	11
<i>Level Control</i>	11
<i>Flow Control</i>	11
<i>INTERNAL CONNECTIONS (for technical personnel only)</i>	12
START-UP	13
VISUALIZATIONS.....	13
OPERATION OF THE ELECTRONIC UNIT.....	14
<i>Standard Configuration</i>	14
<i>Advanced Configuration</i>	14
<i>List of Configuration Parameters</i>	15
<i>Electrochemical Calibration</i>	18
<i>Manual Mode</i>	19
CONTROL EXAMPLES	20
ERRORS / ALARMS	20
MAINTENANCE.....	21
ACCESSORIES AND SPARE PARTS.....	22

PACKING LIST

The EF300 unit is supplied already wired internally, and complete with:

1. pH electrode with plastic body, direct cable and BNC connector with protective sheath
2. ORP electrode with plastic body, direct cable and BNC connector with protective sheath
3. pH and ORP calibration solutions, 90 ml bottles (pH4, pH7 and 220 mV)
4. Two standard kits for electromagnetic pump, including:
 - foot filter and injection valve, with PVDF body and FPM seals
 - PVC Crystal, 4x6 tube for suction and bleed connections, 2+2 meters
 - semi-rigid PE, 4x6 tube for injection line, 2 meters
5. Screws and stoppers for wall installation
6. Instruction manual

INTRODUCTION

EF300 is a compact system easy to install (wall) and maintain, which allows to monitor and control the pH and ORP levels in swimming pools.

The EF300 system includes a digital controller which operates accordingly with the set thresholds, two dosing pumps with input for level sensor, pH and ORP electrodes with BNC connector, and down-flow probe-holder.

INSTALLATION



Warning! Always follow the warnings and general safety information referred at the beginning of this manual!

Install the EF300 unit away from heat sources, in a dry place protected from direct sunlight, at a maximum ambient temperature of 45°C.

The minimum temperature shall be such as to ensure the solution to be dosed remains in a fluid state and in no case less than that declared in the “Technical specifications” section.

The EF300 unit must be installed on a vertical wall and securely clamped. Choose a location that allows easy calibration operations, use and maintenance.

Place the tanks of the products to be dosed below the pumps, without exceeding the maximum suction height of the pumps (about 1.5 m).

If the system is installed below the level of the liquid to be dosed, check the condition of the injection valves or install appropriate anti-siphon kit.

If the pump is placed above the tank and the reagent fumes could be especially aggressive, check the tank seals.



Connect the connectors may be disconnected for packaging reasons to the respective inputs on the bottom of the unit (see the “Functional description” section for further details).

TECHNICAL DATA

pH and ORP Inputs	available on BNC connectors, input impedance > 10 ¹² Ω	
Measure Ranges	0.00 to 14.00 pH, 0 to 1000 mV (ORP)	
Precision	better than 1% of the full scale	
Repeatability	better than 0.2% of the full scale	
Configuration	two configuration level (standard and advanced)	
LEV Inputs	2 independent inputs for level sensors, available on connectors, accept SPDT contact 5 V / 5 mA	
FLOW Input	1 input that can be used for connecting both the filter pump contactor or the flow sensor (SPDT contact 5 V / 5 mA)	
Serial Port	(optional) RS232, available on M8 connector	
Display	large alphanumeric, double row (x 16 characters) LCD, with backlight	
Electrode-holder	down-flow type, transparent methacrylate body, with PP connections for hose 6x8, and sampling valve	
Dosing Pumps	Flow rate: C11 (5 l/h @ 6 bar) or C12 (10 l/h @ 2 bar) Max working frequency: 140 injections/minute Materials: PVDF pump head, PTFE diaphragm, Pyrex ball valves, FPM (or EPDM) seals Max suction height: 1.5 m	
Power Supply	230 V~, 50 Hz ; 100 W	
Protection Fuse	F3.15A 5x20	
Environment	Storage temperature	-20 to +60 °C
	Working temperature	-10 to +45 °C
	RH	max 90% noncondensing
Casing	self-extinguish plastic material with polyester front panel	
Installation	wall installation with supplied screws and stoppers	
Protection Rate	IP65	
Dimensions	380 x 350 x 175 mm	
Fixing Template	356 x 250 mm	
Weight	approx. 5 kg	

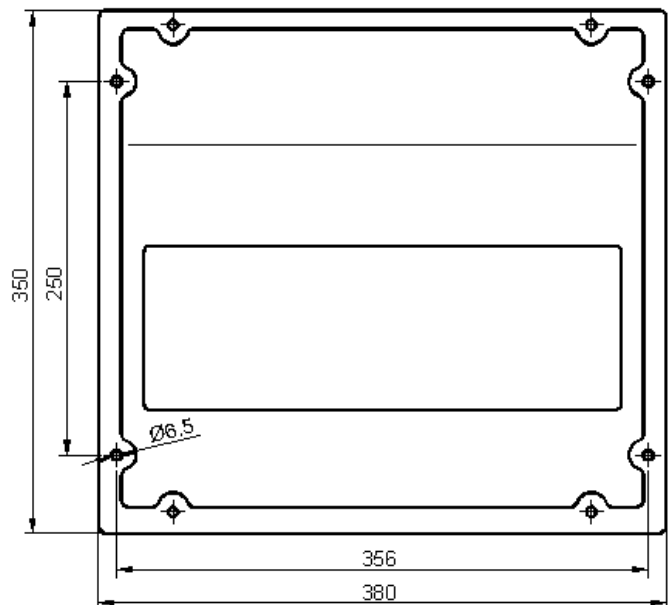

FUNCTIONAL DESCRIPTION OF THE SYSTEM

Front view



- Control panel with large display and keyboard (see description on next page)
- Electromagnetic pump for acid dosage
- Electromagnetic pump for chlorine dosage
- Transparent methacrylate, down-flow type electrode-holder
- pH electrode with direct cable and BNC connector with protective sheath
- ORP electrode with direct cable and BNC connector with protective sheath

Bottom view: connections



POWER	Power cable (prewired)
LEV1	Level sensor connector for acid pump / tank
LEV2	Level sensor connector for chlorine pump / tank
FLOW	Connector for flow sensor
pH	BNC connector for pH electrode
RX	BNC connector for ORP (redox) electrode

Front panel

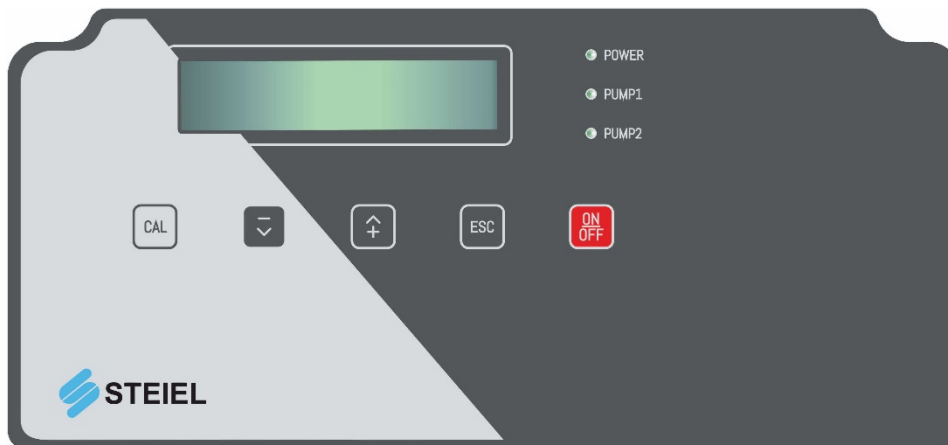

POWER LED	Green light; slow flashing indicates that the unit is powered and normally functioning, while fast blinking indicates a fault (lack of liquid to be dosed or pump magnet disabled)
PUMP1, 2 LED	Red light; lights at each pulse of the corresponding pump magnet
CAL Key	Provides access to the “Configuration”, “Calibration” and “Manual Mode” menus; confirms parameter modifications
↓ Key	Scrolls the available menus/options; in calibration and configuration modes decreases the displayed value; in manual mode decreases the pump working frequency
↑ Key	Scrolls the available menus/options; in calibration and configuration modes increases the displayed value; in manual mode increases the pump working frequency
ESC Key	In calibration and configuration modes exits without saving the modifications; from manual mode resumes to normal operations
ON/OFF Key	Activate / de-activates the unit or confirms alarms; both the disabled dosing or alarm condition are indicated by the POWER LED that flashes fast (Warning! The unit remains disabled even in case of shutdown / restart)

HYDRAULIC CONNECTIONS

Check that the suction line does not exceed the maximum height of 1.5 m from the tank bottom. Unscrew the pipe-wrench nut and remove the two protective caps from fittings (in the case a pump head needs to be removed, it is recommended to reuse the protective caps, to prevent any leakage from the pump body).

Note: If the product to be dosed is concentrated sulfuric acid, previously remove any water from the pump and use polyethylene pipes.

All operations to tighten the pipe connections of the pumps must be done by hand, without using any tools (e.g. pliers squeeze tube), to avoid damaging the hydraulic connections.

Suction Line (also see drawing)

1. Unscrew the fixing nut of the suction fitting (located on the bottom of pump head) and remove the protective cap.
2. Cut the PVC Crystal, transparent tube.
3. Insert the pipe-wrench and tube-press on the tube.
4. Mount the tube on the conic hose of the suction fitting, pushing it until it reaches the stop collar.
5. Fix the tube by screwing the pipe-wrench nut onto the suction fitting of the pump head.
6. Locate the PVC Crystal tube inside the tank and/or the suction lance.
7. Unscrew the pipe-wrench nut of the foot filter.
8. Cut the PVC Crystal, transparent tube.
9. Insert the pipe-wrench on the tube.
10. Mount the tube on the conic hose of the foot filter fitting, pushing it until it reaches the stop collar.
11. Fix the tube by screwing the pipe-wrench nut onto the foot filter fitting.
12. Screw the foot filter onto the suction lance (if used) and/or locate it in its working place.

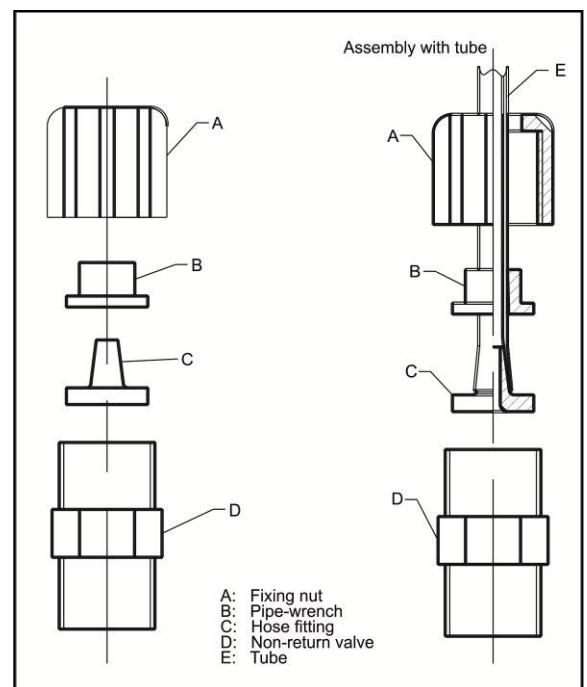

Notes:

- The foot filter must be located at a minimum distance of 5 cm from the tank bottom.
- If a dense product is dosed, it is recommended to remove the small inside filter from the foot valve, in order to facilitate the suction.

Bleed Line

1. Cut the PVC Crystal, transparent tube.
2. Insert the tube on the bleed outlet, located on the right side of the pump head.
3. Insert the other end of the tube in the tank of the product to be dosed, in order to recover the product that comes out when the bleed valve is operated.

Injection Line (also see drawing on the previous page)

1. Unscrew the fixing nut of the head fitting (located on the top of the pump head) and remove the protective cap.
2. Cut the white, semi-rigid, PE tube.
3. Insert the pipe-wrench and tube-press on the PE tube.
4. Mount the tube on the conic hose of the pump fitting, pushing it until it reaches the stop collar.
5. Fix the tube by screwing the pipe-wrench nut onto the head fitting of the pump head.
6. Place the head tube avoiding as much as possible the curves and ensuring that it does not rub against rigid bodies for effect of the pulses.
7. Perform all electrical connections (see related section later in this manual) and power the pump.
8. At the injection point on the pipeline, mount a ½" GAS connection, internally threaded (not supplied).
9. Wrap PTFE tape to the thread and tighten the injection valve to the fitting.
10. Unscrew the pipe-wrench nut of the injection valve fitting.
11. Cut the white, semi-rigid, PE tube.
12. Insert the pipe-wrench on the PE tube.
13. Mount the tube on the conic hose of the injection valve, pushing it until it reaches the stop collar.
14. Screw the pipe-wrench nut onto the valve fitting.

Note: *The injection valve also works as non-return valve: do not disassemble it internally.*

PRIMING

Slightly open the bleed valve and set the manual operation at the maximum dosing frequency, to facilitate priming of the pump.

When the product to be dosed protrudes from the purge tube, close the valve.

Sometimes it is more effective slightly loosen the bleed valve, wait 4-5 seconds, close it, wait a few seconds and repeat the operation.



Warning! *Before performing any kind of operation on the pump, carefully read the HSDS of the chemical to be dosed, in order to define the proper behaviours to be followed, and the personal safety equipment to be worn.*

ELECTRICAL CONNECTIONS

The EF300 unit is supplied already wired internally and complete with power cable (with plug upon request). This is the only electrical connection to be performed by the customer.
Standard power supply: 230 V~, 50 Hz, monophasic.



Carefully follow all the rules of electrical safety.
Before starting the unit, check that all electrical and plumbing connections have been properly executed.

The measure inputs from pH and ORP electrodes are available on BNC connectors, while inputs for level sensors (one for each pump) and flow sensor are available on special connectors that allow an extremely fast and easy connection even for unskilled personnel.

Note: the pH and ORP inputs should never be left open; if an input is not used, you need to short-circuit it.

Level Control

The system is supplied already configured for disabling the dosage in case of low level in the tank. The level control is made through a specific float sensor (optional, see “Accessories and spare parts”), to be connected to pins 3 and 4 of the LEV connector (see Figure)

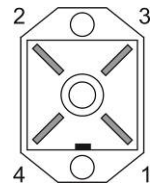

When the product level in the tank falls below the level sensor, the unit stops dosing and the fault is shown on the display.

The alarm condition is generated with a delay of a few seconds compared to the detection of low level, to avoid errors due to extreme situation (such as water surface).

Two inputs for level sensor are available, one for each pump / tank.

Flow Control

The system is supplied already configured for disabling the dosage in case of lack of water flow. The control is made through a SPDT contact to be connected to pins 3 and ⊥ of the FLOW connector (see Figure).

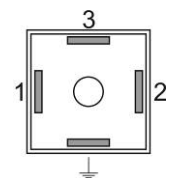

A specific flow sensor is also available (optional, see “Accessories and spare parts”).

Serial Port

The serial port (optional) is wired to an axial connector, for example for the connection to an RW14 supervisor.

The connector configuration is the following:

pin 1 = RX

pin 2 = TX

pin 3 = GND

pin 4 = not used

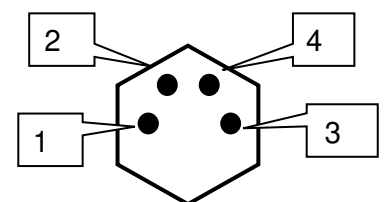

INTERNAL CONNECTIONS (for technical personnel only)

The unit is provided pre-wired internally, and all connections of normal use (power supply, measurement sensors and level sensors) are available externally via cable or connector. However, if you need to operate on the electronic boards or replace blown fuses, refer to the diagram below.

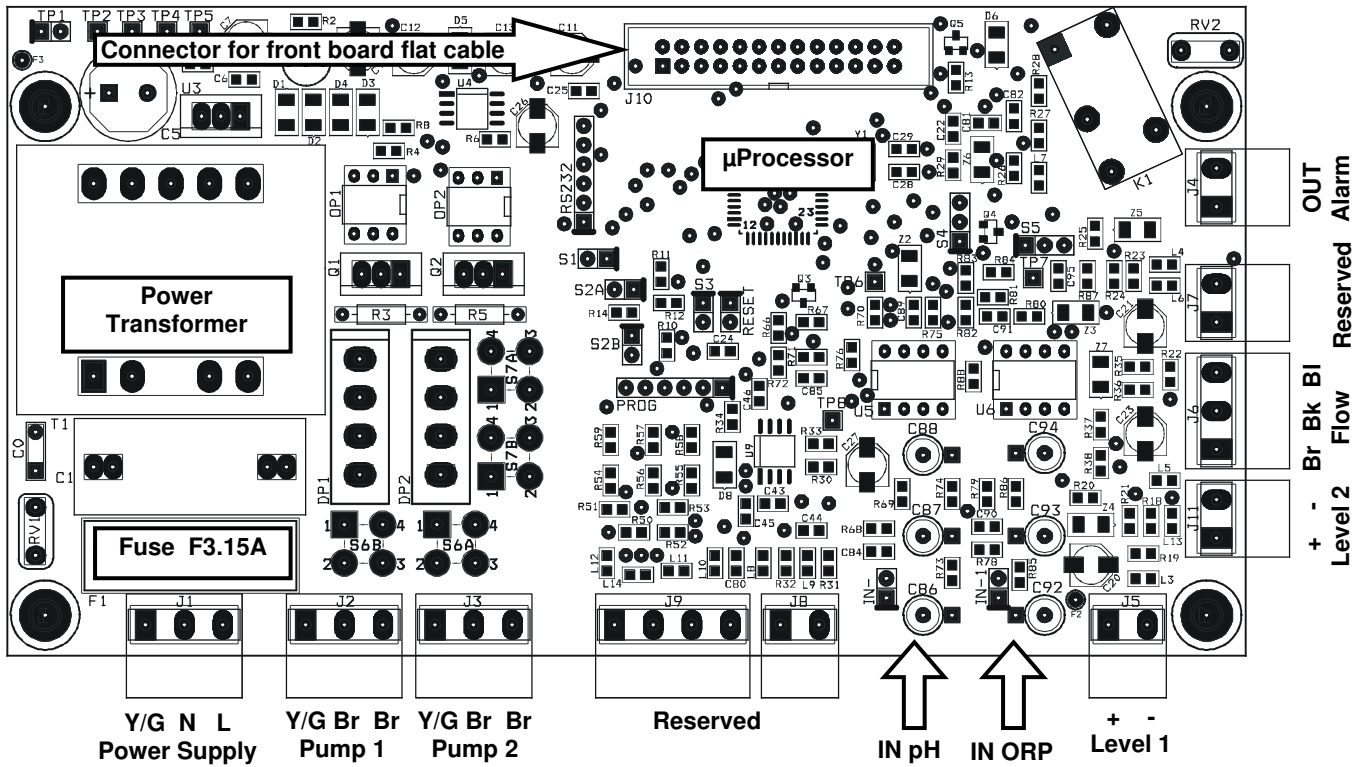

Notes:

- The possible reversal of the connections line / neutral of the power supply does not affect the normal operation.
- If the level and flow inputs are not used, leave them open (not connected).

START-UP

At start-up the microcontroller displays for a couple of seconds information about the firmware (type / version), then shows the two measures flashing for all the start-up delay time (if set) and then starts operating accordingly with the configured working mode.

VISUALIZATIONS

During normal operations, the display shows the two measured values on the top line, while the bottom row displays the status of the two pumps.

For example: “7.25pH 286mV”
 “65i/min 78i/min”

In these conditions, pressing the ↓ or ↑ button, you can display the OFFSET and GAIN values of the pH and ORP measurements.

For example: “7.25pH”
 “O=-4 G=1.000”

This information is useful to verify the electrode status. Note that an electrode in good condition should have an offset close to zero and a gain close to 1.000. When these values deviate from the ideal ones, indicate a dead electrode or sensor aging.

During manual working mode, the display shows on the top line the pump to which the information refers, while the bottom row shows the pump status and working frequency.

For example: “Pump 2 manual”
 “ON 78i/min”

In these conditions, pressing the ↓ or ↑ button, you can respectively decrease or increase the working frequency, while the ON/OFF button allows to enable / disable the pump.

In case of fault or alarm condition, the working frequency is automatically set to “0i/min” and the pump stops dosing until the normal working conditions are restored.

OPERATION OF THE ELECTRONIC UNIT

To access the configuration, calibration and manual mode menus, press the CAL button. The display will show the following available options:

- **Standard Configuration**
- **Advanced Configuration**
- **Calibration IN1 (input 1) pH**
- **Calibration IN2 (input 2) ORP**
- **Manual Mode 1 (pump 1, acid dosage)**
- **Manual Mode 2 (pump 2, chlorine dosage)**

Use the ↓ ↑ keys to scroll the available options, then press CAL to enter the highlighted mode or ESC to return to measurement visualization.



For a complete list of parameters, valid values and related explanations, see the “List of Configuration Parameters” section.

Standard Configuration

The standard configuration mode allows the customer to set a series of parameters related to the normal functioning of the unit. These parameter can be freely accessed and configured from the front keyboard.

- 1) Once selected the “Standard Configuration” option, press the CAL button to edit the list of parameters, or press ESC to return to the normal visualization mode
- 2) Now use the ↑ ↓ keys to scroll the list of the available parameters
- 3) To modify the displayed parameter, press CAL; to quit the mode press ESC

S	T	A	N	D	A	R	D		C	O	N	F	I	G	.
C	A	L	>	Y	E	S			E	S	C	>	N	O	
P	0	1		F	U	N	C	.	T	Y	P	E		P	1
				O	n	O	f	f							

Advanced Configuration

The advanced configuration mode also includes the parameters protected by password, that allow a complete configuration of the system. This mode is normally accessed only by authorized technical personnel.

- 1) Once selected the “Advanced Configuration” option, press the CAL button to edit the list of parameters, or press ESC to return to the normal visualization mode
- 2) Now use the ↑ ↓ keys to scroll the list of the available parameters
- 3) To modify the displayed parameter, press CAL; to quit the mode press ESC

A	D	V	A	N	C	E	D		C	O	N	F	I	G	.
C	A	L	>	Y	E	S			E	S	C	>	N	O	

List of Configuration Parameters

In this section are listed all the configuration parameters.

It is recommended to fill the last column with the values set for your application.

PAR.	Description	Min Value	Max Value	Default Value	Set Value
P01	Functioning Type Pump 1	ON-OFF / Proportional		ON-OFF	
P02	Setpoint Pump 1	0.00pH	14.00pH	7.00pH	
P03	Hysteresis Pump 1	0.20pH	2.00pH	0.50pH	
P04	Dosage Pump 1	Acidification / Alkalinisation		Acidification	
P05	Frequency Pump 1	0 imp/min	150 imp/min	60 imp/min	
P06	Functioning Type Pump 2	ON-OFF / Proportional		ON-OFF	
P07	Setpoint Pump 2	0mV	1000mV	750mV	
P08	Hysteresis Pump 2	20mV	200mV	50mV	
P09	Dosage Pump 2	Chlorination / De-chlorination		Chlorination	
P10	Frequency Pump 2	0 imp/min	150 imp/min	60 imp/min	
P11	Alarm Pump 1	0min	240min	0min	
P12	Alarm Pump 2	0min	240min	0min	
P13	Start Delay	0min	60min	0min	
P14	Language	Italiano - English Français - Español		English	
P15	Autoset	0	255	0	
P16	Password	0	255	0	
P17	Alarm Functioning	Relay NO / Relay NC		Relay NO	
P18	Flow Functioning	Input NO / Input NC		Input NO	
P19	pH Equilibrium	0min	240min	0min	

Warning! The complete list of parameters can be accessed only from the “Advanced Configuration” menu, while the “Standard Configuration” mode allows to modify only the parameters that are not protected by password (highlighted in bold in the table above).

PARAMETER 01 FUNCTIONING TYPE OF THE PUMP 1

This parameter allows to set the functioning type of pump 1, typically used for the pH control.

If the “On-Off” mode is selected, the pump activates automatically when the set threshold is exceeded, working at the set frequency, and stops dosing when the measurement reaches the required value.

If the “Proportional” mode is selected, the instrument calculates the pump working frequency depending on the measured value, then as the measurement approaches the required value, the pump automatically slows down its frequency to a stop. In this way, the desired value can be reached avoiding overdoses due to delays in reading or wrong speed of the dosing pump.

PARAMETER 02 SET-POINT PUMP 1

This parameter allows to enter the desired pH value for the swimming pool water. The dosing pump is activated / de-activated to reach this value and keep it constant.

PARAMETER 03 HYSTERESIS PUMP 1

This parameter is used to adjust the functioning hysteresis of pump 1 around the threshold set in P02. It is recommended to set a narrow window in case of ON-OFF mode, while for proportional mode it is advisable to set a window of at least points.

PARAMETER 04 DOSAGE DIRECTION OF PUMP 1

This parameter allows to set the dosage direction. The choice depends on the product dosed to adjust the pH level: if you dose an acid, set this parameter to “Acidification”, while if you dose a base set “Alkalinisation”.

PARAMETER 05 WORKING FREQUENCY OF PUMP 1

If the pump is configured for ON-OFF mode, this parameter is the working frequency of the pump. If the pump is configured for proportional functioning, this parameter states the maximum working frequency of the pump (when the measurement is far from the set threshold).

PARAMETER 06 FUNCTIONING TYPE OF THE PUMP 2

This parameter allows to set the functioning type of pump 2, typically used for controlling the ORP potential level. See description of parameter P01.

PARAMETER 07 SET-POINT PUMP 2

See parameter P02, but referred to ORP measurements.

PARAMETER 08 HYSTERESIS PUMP 2

See parameter P03, but referred to ORP measurements.

PARAMETER 09 DOSAGE DIRECTION OF PUMP 2

See parameter P04, but referred to ORP measurements and dosing directions “Chlorination / De-chlorination”.

PARAMETER 10 WORKING FREQUENCY OF PUMP 2

See parameter P05, but referred to ORP measurements.

PARAMETER 11 DOSAGE ALARM OF PUMP 1

This parameter allows to generate an alarm when the measurement does not return to the setpoint value within a set time interval, from 0 (function disabled) to 240 minutes. The counter starts when the unit detects a measurement that exceeds the setpoint value, and automatically resets to zero when measurement returns to an acceptable. If measurement remains outside of the setpoint for a time longer than that set, an alarm is generated, the display shows the message “AL.1” and the pump stops dosing. To reset the alarm and resume to normal operations, press the ON/OFF button or shutdown and restart the unit.

This condition can occur when the dosage is insufficient to reach the setpoint (P02).

PARAMETER 12 DOSAGE ALARM OF PUMP 2

See parameter P11, but referred to pump 2.

PARAMETER 13 START-UP DELAY

This parameter allows to set a start-up delay, which is a time of waiting before starting measurements to allow the correct polarization and stabilization of the measuring electrodes. This prevents unreliable initial readings. Typically in the case of pH measurements one minute is enough, while for ORP electrodes may be necessary a delay of 30 minutes. This waiting time also allows to compensate for any hydraulic delays which may occur at the start-up of the plant.

Set a time (in minutes) during which, after turning on the electronic unit, the system waits, measurements blink on the display and the pumps are not active. After this time, the system begins normal operation.

PARAMETER 14 LANGUAGE

This parameter allows to select the display language.

PARAMETER 15 AUTOSET

This feature allows to restore the factory configuration if you want to delete incorrect or undesired settings. Once confirmed this option, all custom setting will be lost.
To enable the feature, enter the value “12” .

PARAMETER 16 PASSWORD

This parameter allows to enter a password (numeric value within 1 and 255) to protect the system from unauthorized access. Once set and confirmed, the password will be requested to access the menus “Advanced configuration” and “Manual mode”.
The instrument is supplied with no password set (P16=0).
Warning! If you forget the password, you need to send back the unit to the factory for a complete reconfiguration (out of warranty)!

PARAMETER 17 FUNCTIONING OF THE ALARM OUTPUT

This parameter allows to select the functioning mode of the alarm relay, normally open “NO” (factory setting) or normally closed “NC”.

PARAMETER 18 FLOW FUNCTIONING

This parameter allows to select the functioning mode of the “flow” input, normally open “NO” (factory setting) or normally closed “NC”.
Warning! The inversion of this parameter compared to the default setting can determine the functioning of the device even in the absence of flow!

PARAMETER 19 pH EQUILIBRIUM

This parameter allows to set a maximum waiting time before activating the ORP (chlorine) adjustment, during which only the pH adjustment is active.
This time is counted from the start-up of the equipment, simultaneously to a possible start-up delay set in P13, during which the entire measuring system is in stand-by.
In other words, the pH adjustment is activated after the start-up delay (P13) has elapsed, while the ORP (chlorine) regulation is activated when the pH reaches the set threshold (P02) or in any case at the end of the “pH Equilibrium” period.
For example, if a 1-minute start-up delay is set and you want the pH is adjusted for a maximum of 15 minutes before also activate the ORP (chlorine) regulation, the “pH Equilibrium” time should be set to 16 minutes.
To disable this feature, simply set the parameter to 0 (default).

Notes:

- *Once in configuration mode, if no button is pressed for 30 seconds, the unit automatically returns to the idle mode.*
- *The system is factory configured with default values; you can delete undesired settings and restore the initial configuration, using the “AUTOSET” function (P15).*

Electrochemical Calibration

pH Calibration

- 1) Rinse the pH electrode with distilled water, then immerse it in the pH 7.01 pH buffer solution
- 2) Press the CAL key to enter the menu mode and use the \uparrow \downarrow keys to select the option "IN1 CALIBRATION"

I	N	I		C	A	L	I	B	R	A	T	.		P	H
C	A	L	>	Y	E	S				E	S	C	>	N	O
- 3) Press CAL again to confirm
- 4) Press \downarrow to select the OFFSET calibration and confirm by pressing CAL

I	N	I		C	A	L	I	B	R	A	T	.		P	H
\downarrow		O	F	F	S	E	T		\uparrow		G	A	I	N	
- 5) The system automatically recognizes and displays the buffer value (7.01 pH)
- 6) If necessary, use the \uparrow \downarrow keys to adjust the calibration value
- 7) Press CAL to confirm the calibration, or ESC to quit the procedure and keep the previous calibration
- 8) Rinse the pH electrode with distilled water, then immerse it in the pH 4.01 (or 9.01) buffer solution
- 9) Press the CAL key to enter the menu mode and use the \uparrow \downarrow keys to select the option "IN1 CALIBRATION"

I	N	I		C	A	L	I	B	R	A	T	.		P	H
C	A	L	>	Y	E	S				E	S	C	>	N	O
- 10) Press CAL again to confirm
- 11) Press \uparrow to select the GAIN calibration and confirm by pressing CAL

I	N	I		C	A	L	I	B	R	A	T	.		P	H
\downarrow		O	F	F	S	E	T		\uparrow		G	A	I	N	
- 12) The system automatically recognizes and displays the buffer value (4.01 or 9.01 pH)
- 13) If necessary, use the \uparrow \downarrow keys to adjust the calibration value
- 14) Press CAL to confirm the calibration, or ESC to quit the procedure and keep the previous calibration

Notes

- If the system does not automatically recognize the buffers or the "Calibration Impossible" error occurs, it can be due to:
 - a) buffer solution contaminated or expired
 - b) electrode faulty or dead
 - c) connection cable or connector damaged
- If you try to calibrate the offset at a pH value too different from 7.00, the calibration is automatically ignored. Similarly if you try to calibrate the gain with a buffer solution at a pH too close to neutrality, the procedure will fail.
- During normal operation, it is possible to view the offset (pressing \downarrow) and gain (pressing \uparrow) values, to check the electrode status. The ideal values are an offset close to zero and a gain close to 1.000. When these values are close to the max / min limits (offset: -1.00pH ... +1.00pH; gain: 0.750 ... 1.500), the electrode is contaminated or dead.

ORP Calibration

- 1) Rinse the electrode with distilled water, then immerse it in the calibration solution (e.g. 220 mV)
- 2) Press the CAL key to enter the menu mode and use the ↑ ↓ keys to select the option “IN2 CALIBRATION”
- 3) Press CAL again to confirm
- 4) Press ↓ to select the OFFSET calibration and confirm by pressing CAL
- 5) The system automatically recognizes and displays the solution value (220 mV)
- 6) If necessary, use the ↑ ↓ keys to adjust the calibration value
- 7) Press CAL to confirm the calibration, or ESC to quit the procedure and keep the previous calibration

I	N	2		C	A	L	I	B	R	A	T	.		R	X
↓				O	F	F	S	E	T						
I	N	2		C	A	L	I	B	R	A	T	.		R	X
C	A	L	>	Y	E	S				E	S	C	>	N	O

Notes

- If the system does not automatically recognize the buffers or the “Calibration Impossible” error occurs, it can be due to:
 - a) calibration solution contaminated or expired
 - b) electrode faulty or dead
 - c) connection cable or connector damaged
- During normal operation, it is possible to view the offset value by pressing ↓, to check the electrode status. The ideal offset value is close to zero. When this value is close to the max / min limits (-100mV ... +100mV), the electrode is contaminated or dead.

Manual Mode

At any time you can force the system to manual working mode.

This type of operation is very useful during the pump priming or for a temporary use of the system in manual mode.

If a password has been set (see parameter P16), the system will require it to enable the access to this feature.

- 1) Press the CAL key to enter the menu mode and use the ↑ ↓ keys to select the option “MANUAL FUNC.1” (or “MANUAL FUNC.2”)
- 2) Press CAL again to confirm
- 3) Use the ↑ ↓ keys to adjust the working frequency (pulses per minute) of the pump, or press the ON/OFF button to enable/disable the pump
- 4) Similarly proceed for pump 2
- 5) Press ESC at any time to exit the manual mode

M	A	N	U	A	L		F	U	N	C	.		P	1	
C	A	L	>	Y	E	S				E	S	C	>	N	O
M	A	N	U	A	L		P	U	M	P			1		
O	F	F				0	i	/	m	i	n				



Warning! In manual mode only one pump at a time can be activated.

CONTROL EXAMPLES

Typical application in swimming pool control: acidification when pH exceeds the pH value of 7.30.

Refer to the “List of configuration parameters” and set:

- P01 → ON/OFF working mode for pump 1
- P02 → set-point 7.30 pH
- P04 → dosage direction “ACIDIFICATION”
- P05 → if the quantity of the product to be injected is not known, it is recommended to start with a low working frequency (e.g. 20 pulses/minute), and if the acidification process would last too long, increase the frequency gradually until a conditioning time of approx. 30-45 minutes
- P11 → alarm pump 1 = 60 minutes

Typical application in swimming pool control: chlorination when ORP value falls below 680 mV. Refer to the “List of configuration parameters” and set:

- P06 → PROPORTIONAL working mode (recommended for an easier stabilisation)
- P07 → set-point 680 mV
- P09 → dosage direction “CHLORINATION”
- P10 → if the quantity of the product to be injected is not known, it is recommended to start with a low working frequency (e.g. 20 pulses/minute), and if the chlorination process would last too long, increase the frequency gradually until a conditioning time of approx. 30-45 minutes
- P12 → alarm pump 2 = 60 minutes

Common settings for the two examples described above:

- P13 → start-up delay of 15 minutes (average time required for the polarization of ORP electrodes)
- P16 → protection PASSWORD to prevent unauthorized access

ERRORS / ALARMS

Every error or anomaly detected by the system generates an alarm message on the display:

LEV1 / LEV2	The level sensor 1 or 2 detected a low level of the liquid to be dosed; restore the level into the related tank
FLOW	The flow sensor detected an anomaly that can be due to low pressure into the hydraulic circuit or wrong adjustment of the flow sensor in the electrode-holder; restore the flow or adjust the sensor
STOP	This message indicates that the pumps have been manually deactivated by pressing the ON/OFF button
UR / OR	Under/Over Range: measurement out of range; this signal can be generated by a dead or broken electrode, or by a damaged or disconnected cable; check the system and restore correct measurement conditions
AL.1 / AL.2	Dosing time alarm for pump 1 or 2: measurement is outside the set-point for a time longer than the set limit, due to an insufficient dosage or a wrong configuration of the alarm time (see parameters P11 and P12); set the parameters properly
Calibration Impossible	Check the status of electrode and connection cable; check that the calibration solutions are not expired or contaminated; repeat the procedure

MAINTENANCE

The periodic maintenance operations are essential for the proper functioning of the system and its duration in time. The below advices should be strictly followed.



Before any operation, make sure the system is unplugged!

Dosing Pumps

For a perfect seal, after about 800 hours of work, it is recommended to tighten the bolts of the pump by applying a torque of 2.5 Nm.

Weekly operations:

- Check the level of the solution to be dosed to prevent the pump from running dry
- Check that the suction and head pipes are clean and not containing any impurities
- Check that the filter is not clogged to avoid the decreasing of flow rate

Operations every three months (or in case of pump drifting):

- Clean all the parts that come into contact with the chemical (pump body, foot filter and injection valve). If the pump doses additives that form crystals, clean more frequently.

Proceed as follows:

- o Dip the suction tube and the foot filter into clean water
- o Start the pump and leave it run for a few minutes to let the water wash the pump head

If there are crystals to remove, proceed as follows:

- o First use a proper chemical (instead of water) to dissolve the crystals (e.g. hydrochloric acid for sodium hypochlorite crystals) and let the pump work for a few minutes
- o Repeat the procedure with clean water

Once the cleaning is done, connect again the pump to the plant and resume normal operations.

Replacement of worn parts:

- Valve replacement:
 - o Unscrew the upper and lower connections using a 24 mm spanner
 - o Install and tighten the new fittings
- Replacement of the pump head O-ring and diaphragm: this maintenance must be performed only by authorized personnel - Contact the technical service
- Fuse replacement: this maintenance must be performed only by authorized personnel - Contact the technical service

pH and ORP Electrodes

Typically, it is recommended to clean the electrodes when the response is slow or measurements are not reliable, and when they have been used for a long time, especially in aggressive solutions, pollutants, very acidic or very alkaline environments.

STEIEL provides a kit of solutions for the cleaning and storage of pH and ORP electrodes.

The kit includes three solutions:

- Solution A: dip the electrode in this solution for cleaning it
- Solution B: use this solution to rinse the electrode, before and after cleaning
- Solution C: storage solution to be used for filling the electrode protective cap when the electrode is not used (wintering, closure of the plant)

ACCESSORIES AND SPARE PARTS

Item	Description	Code
pH Electrode	pH electrode with plastic body, direct cable and BNC	80094111
ORP Electrode	ORP/Pt electrode with plastic body, direct cable and BNC	80194111
SDE	Transparent methacrylate, down-flow probe-holder with PP connections for hose 6x8, and sampling valve	80610258
Flow control kit for SDE electrode-holder		97009203
EFK1-PGV	Complete PVDF pump head with Pyrex ball valves and FPM seals, for pumps EF-C11/C12	97002101/PGV
EFK2-PGV	Kit of suction / head valves with PVDF body, Pyrex ball and FPM seals, for pumps EF	97002000/PGV
EFK3-PGV	Kit of suction / head / purge valves and O-ring for pump head. PVDF valves with Pyrex ball, FPM seals and O-ring	97002001/PGV
EFK4	Maintenance kit including flange, PTFE diaphragm for pumps EF-C11/C12, and FPM O-ring for pump head	97002021
EFK5	Kit purge with PVDF valve and FPM seals	97002025
EFK6-PGV	Standard accessory kit for pumps with FPM seals, including: foot filter and injection valve with PVDF body and Pyrex ball, 4x6 PVC Crystal tube (2+2 m), 4x6 in PE tube (2 m)	97002010/PGV
SLP2	Level sensor with 2 m cable and connector	97009002
pH4-S	pH 4 buffer solution, 90 ml bottle	80090095
pH7-S	pH 7 buffer solution, 90 ml bottle	80090096
RX220-S	ORP calibration solution (220 mV), 90 ml bottle	80190091
KRE	Cleaning and storage kit for pH and ORP electrodes	80099902

Note: The spare parts / maintenance kits for pumps are also available with EPDM or PTFE seals.