

## SUCTION LANCES

To complete the range of accessories for dosing stations, **adjustable length** suction lances are available, provided with built-in non-return valve and **level probe**, suitable for dosing stations with **tanks up to 1000 litres**.

- **Flow rate up to 100 L / h**
- Mounting with 1" threaded ring or sleeve
- PP-PVC-NBR body, FPM (standard) or EPDM gaskets
- **Inbuilt non-return valve** with Pyrex ball (standard), PTFE or ceramic
- **Level sensor with 2 m cable totally protected** and connector
- Threaded ring colour: black (standard), blue, red, or yellow
- Connection for hose 4x6 (standard), 5x8 or 9x12 mm
- Working temperature: max 50 °C

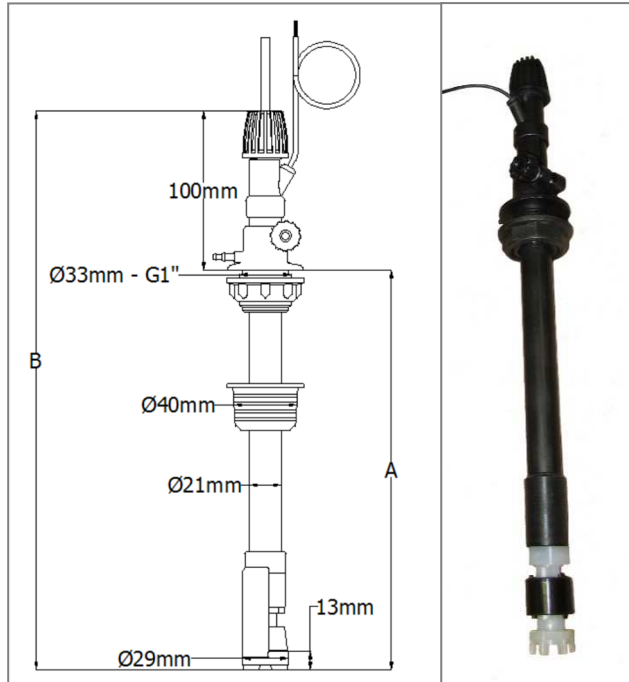

Item	Tank (volume)	Length (mm)	
		Total (B)	Adjustable (A)
Suction lance with FPM gaskets, Pyrex ball valve, connection for hose 4x6 mm and black threaded ring	25 / 50 L	490	115 ... 390
	100 L	700	115 ... 600
	150 / 300 L	940	115 ... 840
	500 / 1000 L	1420	115 ... 1320

*Coding system*

**949 Suction lances**

**Connector for level sensor**

- 1 Solder type, for EF110 / EF150 / EF155 pumps and Compac control units
- 5 Plastic M8 for NOVA / PROXIMA PSP / EF160 EVO series pumps

**Colour of threaded ring**

- 0 Blue
- 2 Black**
- 4 Red
- 5 Yellow

**Connection for hose**

- 1 4x6 mm**
- 2 5x8 mm
- 3 9x12 mm

**Materials (valve ball / gaskets)**

- 0 Pyrex / FPM**
- 1 Pyrex / EPDM
- 4 ceramic / FPM
- 5 ceramic / EPDM
- 6 PTFE / FPM
- 7 PTFE / EPDM

**Total length (tank volume)**

- 1 490 mm (25 / 50 L)
- 2 700 mm (100 L)
- 3 940 mm (150 / 300 L)
- 4 1420 mm (500 / 1000 L)

*Note: Standard options are highlighted in bold.*

**Example of a code building:.....94952102**

- Suction lance .....949
- With M8 connector .....5
- Black threaded ring .....2
- Connection for hose 4x6 mm .....1
- Valve with Pyrex ball, FPM gaskets .....0
- For 100 L tank .....2