



Hardness Analyzer

(basic version)

TECHNICAL MANUAL



WARNINGS



This manual is dedicated to the technical personnel responsible of the installation, management and maintenance of the plants. The manufacturer assumes no responsibility for damages or malfunctions occurring after intervention by non-authorized personnel, or not compliant with the prescribed instructions.



Before performing any maintenance or repair action, ensure that the system is electrically and hydraulically insulated.



Dispose of waste material and consumables accordingly with local regulations.

GENERAL SAFETY TIPS



WARNING! Before performing any operation on the unit, unplug the system and discharge the liquid from the equipment. **Never operate on working devices!**



During maintenance and repair of parts that normally become in contact with chemicals, always wear all prescribed personal protections (gloves, clothes, glasses, etc.). The unit has to be handled by qualified personnel only. Always use original spare parts for maintenance.

Failure to follow instructions can cause damage to the equipment and, in extreme cases, to people.

How to ship the unit

To send back the device for repairing or calibration purposes, proceed as follows:

- Fill the module “REPAIR REQUEST AND DECONTAMINATION DECLARATION” supplied with this manual, and include it in the transport documentation.
- Clean the device properly, to eliminate any hazardous residuals.

The manufacturer can modify the instrument or the technical manual without advanced notice.

Warranty

All STEIEL products are warranted for a period of 12 months from the delivery date.

Warranty is not valid if all instructions of installation, maintenance and use, are not strictly followed by the user. Local regulations and applicable standards have also to be followed.

In particular, the warranties regarding the operational safety and reliability of the unit will be recognized only if the following conditions are fulfilled:

- The installation, wiring, adjustment, maintenance and repairs performed only by qualified personnel
- The unit was used according to instructions provided in this manual
- Only original spare parts have been used for repairs

TABLE OF CONTENTS

<i>INTRODUCTION</i>	4
<i>GENERAL SAFETY</i>	4
<i>TECHNICAL DATA AND OPERATION CONDITIONS</i>	6
<i>TEST RESULT</i>	7
<i>ACCESSORIES</i>	7
<i>UNIT OVERVIEW</i>	8
<i>PRINCIPLE OF OPERATION</i>	10
<i>INSTALLATION AND COMMISSIONING</i>	12
<i>START-UP AND CONFIGURATION</i>	18
<i>MAINTENANCE AND SERVICE</i>	29
<i>ERRORS</i>	31
<i>SPARE PARTS AND REAGENTS</i>	33
<i>ANNEX 1: CALCULATION TABLE FOR WATER HARDNESS</i>	35
<i>ANNEX 2: INSTRUCTIONS FOR DISPOSAL</i>	35

INTRODUCTION

This compact system is an **on-line analyzer** for the continuous control of water quality. Built for automatic operations and ease of use, the analyzer works on the principle of the “limit value” using a colorimetric indicator.

This system is designed for industrial application, and can give a maximum limit value indication of the potable water hardness (total or carbonate hardness).

This handbook contains the instructions for the use and operation of the **analyzer**. Please read these instructions carefully before operating the unit. We will not accept any liability for damage caused by operator error or failure to follow the instructions found in this handbook.

The installation, electrical connections and configuration of the system must be carried out only by qualified technical personnel.

The connection cables to the sensors must be kept as short as possible, and separated from power cables. Some harsh industrial environment may require an appropriate shielding against electromagnetic fields and interferences.

Some details and instructions in this handbook may vary slightly from the delivered unit. We reserve the right to make technical changes to improve our products without prior notice.

GENERAL SAFETY



Carefully read and follow all safety instructions before operating the unit!

This section will give you all necessary information for proper use, installation and maintenance of the **analyzer**, in order to ensure safe and easy operations.

Dangers may result from incorrect use. Anyway, the reading of all safety instructions and prescriptions does not replace technical training. **The installation and maintenance of this unit should only be carried out by an authorized and qualified technician.**

The **analyzer** may only be used in accordance with the conditions described in this handbook. In particular, the unit must be protected from wet and damp.

The protection rate of the unit on open mounting plate is IP43, while the unit installed in the protective case achieves an IP54 level. Splashing or condensation should be avoided.

The unit may only be used for the specified purpose. During installation and operation of the analysis unit, the relevant regulations (e.g. EN, DIN, VDE, UVV) should be observed.

The analysis unit should only be used to measure the total water hardness or the carbonate hardness in the sample water. **Correct operation can only be warranted if the original recommended reagents and spare parts are used.**

Changes to the electrical wiring and configurations should only be carried out by an authorized and qualified technician.

Connection cables should be as short as possible and kept separated from power cables. Analysis may be affected by strong electromagnetic fields. In this case special protective measures should be applied. A proper grounding of the system is critical.

It is recommended to keep on hand these operating instructions during the start-up of the equipment, in order to get an immediate understanding of the functions.

Working with Pipes Under Pressure

Maintenance and repair operations should be carried out by qualified personnel only.

- Before starting any operation, make sure that the pipes are not under pressure
- Regularly check pipes, joints and seals, and – if necessary – replace them; always observe recommended maintenance intervals
- After any maintenance intervention and before resuming normal operations, ensure that all joints, fittings and seals are correctly fitted; check that all casing parts are closed, and filters and any other part connected to the unit are correctly installed
- Before resuming normal operations, remove all maintenance tools and other materials
- Clean the unit and wipe up any liquid leakage
- Check that all safety systems are correctly located and properly working

Transport

Protect the analysis unit during transport. Remove any remaining fluids. Remove the reagent bottle and firmly close it to avoid any spillage. Transport unit carefully and do not throw it.

Avoid direct sunlight, moisture and high temperatures.

Immediately on delivery, check that the unit is complete and has no damage. Even though the unit is well packed, damage can occur during transport. In case of damage, immediately inform the deliverer.

Storage

Store the analysis unit in a cool, dry place, at a temperature between 5 and 45°C. Avoid direct sunlight.

Installation

Follow the below sequence:

1. Inspect the installation area and ensure it is a dry and easily accessible location
2. Drill the necessary mounting holes (see mounting diagram), hang and secure the analyzer
3. Connect water inlet and outlet
4. Configure the device and set the washing (see instructions)
5. Connect the power cable (check the required power voltage)
6. Power the device
7. Open the inlet water line and check for leakages
8. Perform some manual tests and proceed only when a good performance is reached
9. Switch off the device and connect the sensors, and any other external device, as for example an alarm signal
10. Switch on the equipment, check the signals and operations

TECHNICAL DATA AND OPERATION CONDITIONS

The analyzer automatically checks if the set limit value has been exceeded or not. It is recommended to read this section before installing / starting the system.

Power Supply	230 V~, 50/60 Hz or 24 V ~/-
Power Consumption	25 VA (during analysis)
Protection Degree	IP43 or IP54 (version with protective housing)
Environment	Working Temperature 5 ... 40 °C Storage Temperature 0 ... 45 °C RH 20 ... 90% no condensing
Water Temperature	5 ... 40 °C
Inlet Water Pressure	approx. 0.5 ... 5 bar (1 ... 2 bar recommended)
Inlet Water Quality	transparent, colourless, free from suspended solids, air bubbles or carbon dioxide pH 4 ... 10.5 ; iron < 3 ppm ; copper < 2 ppm ; aluminium < 0.1 ppm ; manganese < 0.2 ppm, acid constant $K_{S4.3}$ < 5 mmol/L
Hydraulic Connections	water inlet / outlet: flexible tube with OD 6 mm (not supplied); free discharge with no counter-pressure Note: Use suitable industrial tubes
Installation	Wall mounting, indoor
Dimensions	280 x 250 x 140 mm / approx. 1.6 kg 300 x 300 x 190 mm / approx. 1.9 kg (with protective housing)
Analysis Method	colorimetric
Maximum Value	this limit is defined by the indicator used (500 ml bottle) Total hardness , max value: 0.09, 0.18, 0.36, 0.54, 0.9, 1.8, 3.6, or 5.4 † Carbonate hardness , max value: 1.8, 2.7, 3.6, or 5.4 †
Indicator Consumption	< 0.10 ml/analysis
Indicator Shelf Life	2 years
Water Consumption	approx. 1000 ml/analysis (also depending on washing time and water pressure)
Relay Outputs	3 relays (limit exceeded, malfunctioning, analysis in progress), NC/NO voltage-free contacts, 250 V~/-, 4 A
Digital Input	voltage-free contact, max load 24V, 10 mA

TEST RESULT

The analyzer works with a single-component indicator, which features a specific limit value (see below table for details). To set a different alarm limit, you just need to change the indicator without reconfiguring the system. The indicator has a 2-year shelf life if correctly stored in a cool and dark place, with the bottle closed. After opening the bottle, the product should be used within 12 months.



The temperature of tested water must not be higher than 40 °C. If necessary, add a cooler.

Indicator Type	Colorimetric reaction in the analysis chamber	
	Result: GOOD water. Limit not exceeded	Result: BAD water. Limit exceeded
Total hardness	GREEN	RED
Carbonate hardness	YELLOW	VIOLET
Plus m-value	ORANGE	BLUE

If the S9 switch is moved to the ON position, the result is reversed as follows:

- GOOD water = limit exceeded
- BAD water = result below the limit

ACCESSORIES

Cleaning set for analysis chamber	
<p>Pre-cooler (water < 80°C)</p> <ul style="list-style-type: none"> • Body: Stainless steel 1.4571, 103 x 225 mm • Cooling coil: Stainless steel 1.4571, 2.6 m x 8 mm 	
<p>Pre-cooler (water > 80°C)</p> <ul style="list-style-type: none"> • Body: Stainless steel 1.4571, 103 x 448 mm • Cooling coil: Stainless steel 1.4571, 5 m x 8 mm 	

UNIT OVERVIEW

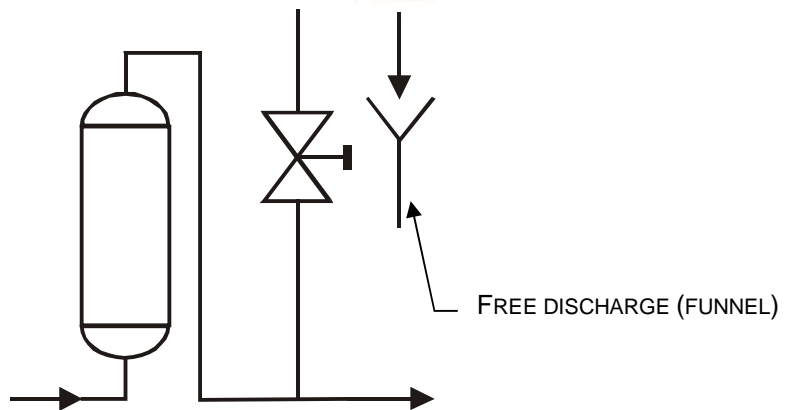
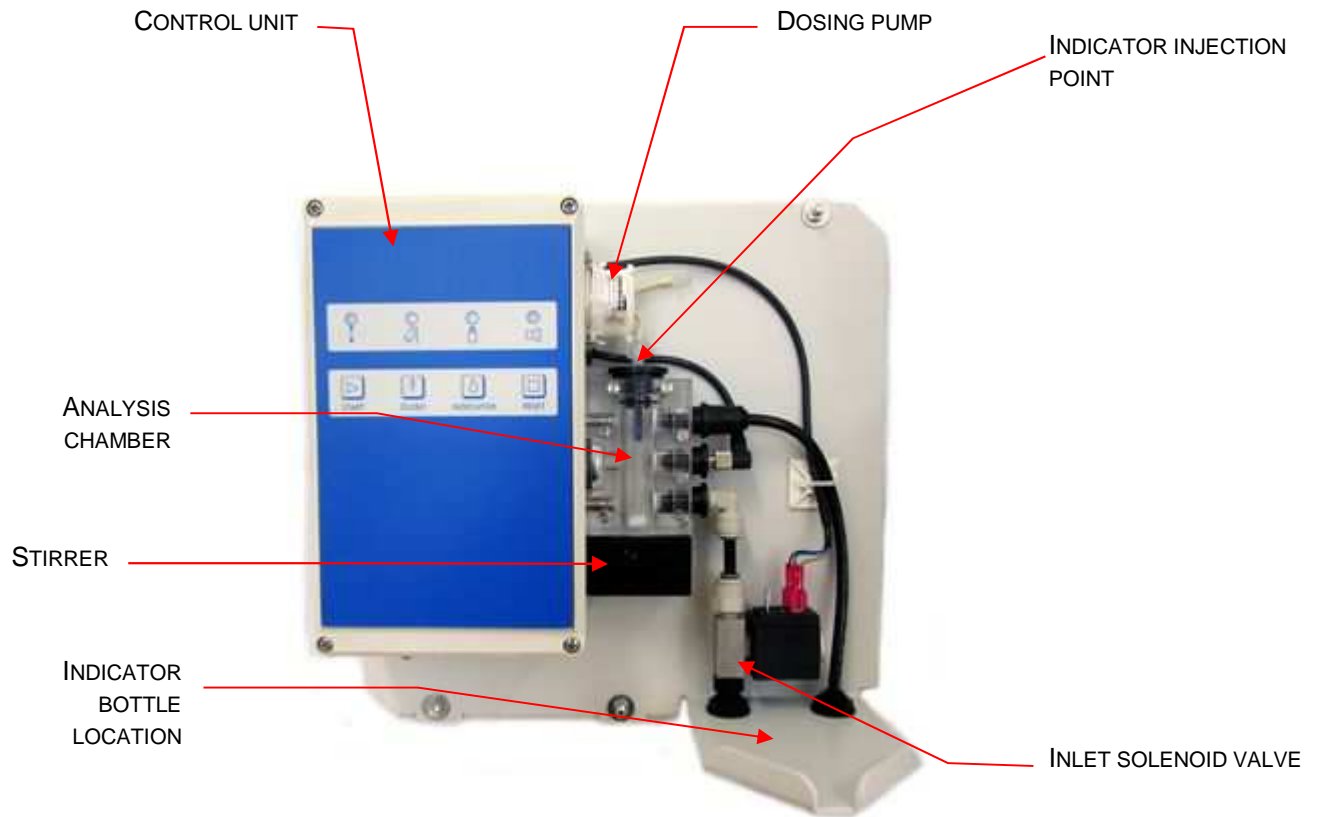

WATER TREATMENT PLANT,
FOR EXAMPLE: WATER SOFTENER

INLET WATER PRESSURE : 0.5 ... 5.0 BAR
RECOMMENDED : 1 ... 2 BAR

LED DISPLAY



EVALUATION RESULT
 GREEN GOOD CONDITION / POWER ON
 RED BAD CONDITION

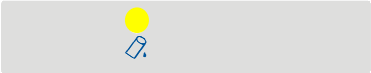

YELLOW ANALYSIS IN PROGRESS



BLUE LACK OF INDICATOR

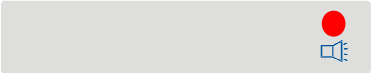

RED ALARM



CONTROL BUTTONS



START MANUAL ANALYSIS



FLUSH MANUAL WASHING



INDICATOR MANUAL INDICATOR
 DOSAGE



RESET RESET ALARM

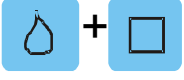

NEW INDICATOR BOTTLE

PRINCIPLE OF OPERATION

A monitoring cycle is performed in 5 steps:

- [1] Pause time between two analyses:
Can be set at 5, 10, 20 or 30 minutes
- Analysis delay:
Can be set in the range 0 ... 30 minutes
- ↓
- [2] Washing the analysis chamber:
Set a time from 5 seconds to 30 minutes
- ↓
- [3] Zero Test:
The analysis chamber is filled with sample water without adding the indicator
- ↓
- [4] Dosing the indicator and mixing with sample water
- ↓
- [4.1] Water analysed through light transmittance detection, and resulting colour compared with the appropriate references
- ↓
- [5] Flushing the analysis chamber
- Timed analysis: set the pause time between two analyses.
Delay: allows cooling the water before starting the analysis. The relay no. 3 opens the cooling water inlet valve. The delay time allows to lower the water temperature at a value < 40°C. Only when this delay has elapsed, the analyser valve opens.
- The inlet valve opens and the analysis chamber is washed, and softened fresh water enters.
- This test allows to check the water transparency and compensate (if possible) for electromagnetic interferences, water not completely transparent, or other inconveniences.
Indicator is not dosed.
In case of error (water not transparent, electrical error of light emission, optical reading error, etc.), an alarm is triggered.
- The indicator is dosed and mixed with the sample water, then a colorimetric reaction takes place. In case of water lack, dosage lack, expired indicator, unexpected chemical reaction, or operation error, an alarm signal is generated.
- Depending on the water resulting colour, the LED indicator will be green or red.
Green = the result is below the max limit of the indicator used.
Red = the result exceeds the max limit of the indicator used.
- NOTE: if the S9 switch is moved to the ON position, the result is reversed (green light: result above the limit / red light: result below the limit)
- The analysed water is discharged and the chamber washed, leaving only clean water inside the chamber.

Available analysis modes:

- A. automatic, scheduled at fixed time intervals of 5, 10, 20 or 30 minutes
- B. manual, by pressing START
- C. triggered by an external switch (if the S10 switch is in ON position)

The analyser may be stopped and controlled through the STOP contact.
This function is useful during the regeneration of the softening system, in case of discontinuous use of the RO plant, etc.
The STOP command can be activated only if the S10 switch is in OFF position.

Main Features of the Hardness Analyzer, Basic Version

- Automatic detection of the softening system's exhaustion, related to the indicator used. The analysis is fully automatic, and more reliable and direct than manual or indirect methods.
- The system does not require periodic calibration.
- The analysis frequency (interval) can be set at 5, 10, 20 or 30 minutes. The analysis may also be triggered by an external consent.
- Reliable and accurate readings using the appropriate indicator.
- After a "BAD water" result, the analysis can be repeated within 4 minutes, prior to generate an alarm signal.
- LED signals are clear and language-independent.
- An alarm is generated if the max limit value is exceeded. The relay no. 1 can activate an acoustic signal, start a regeneration process of the softener, close a solenoid valve, or send the signal to a control unit.
- Diagnosis function: if any technical failure occurs, the relay no. 2 is activated. The operator can use the diagnosis program to check step by step the system operation and individuate the cause of malfunctioning.
- Minimal maintenance required: the measurement chamber needs to be cleaned depending on the analysis frequency and water quality. Cleaning also includes the replacement of O-rings and dosage tubes. Anyway, O-rings and tubes should be replaced once or twice a year.
- Minimal consumption of indicator: typically, a 500 ml indicator bottle lasts approx. 3 to 4 months. Bottle replacement is a very easy operation.
If the analysis interval is 3 minutes, a more frequent replacement may be required.
- Easy installation and start-up, to be performed by a qualified technician, who knows hydraulic connections and wiring.
- **IN Input:** This input can be used to stop the analyser through an external signal (timer, switch, flow meter, level sensor, etc.). When contact opens, the analyser stops operations.
- **Relay Outputs** (Voltage-free contacts)
REL1 = alarm upon limit exceeded (or hardness below the limit with S9 properly configured)
REL2 = failure
REL3 = analysis in progress

"BOB" Operation

The acronym BOB means "Betrieb ohne Beobachtung", i.e. "Operation without Observation", which is a special term of German TÜV rules. These rules require that the analysis unit is provided with enough reagent for operating for 72 hours without any external intervention.

The relay 2 can be used to activate an alarm signal.

Warning! For the "BOB" operation, each replacement of indicator bottle (500 ml) must be confirmed by pressing the "INDICATOR" and "RESET" buttons simultaneously. The device does not detect the indicator level, and, therefore, this confirmation is needed for calculating the indicator consumption starting from 500 ml and according to the system settings.

Warning! Do not confirm the replacement if the 500 ml bottle is not full.

INSTALLATION AND COMMISSIONING

Installation Requirements

The unit has to be used only for analyzing potable water.

A proper operation can only be ensured if using an original indicator, supplied by the manufacturer. Configuration and wiring should be performed only by qualified technical personnel.

Strictly follow the below prescriptions:

- Never exceed the maximum load of contacts
- Inductive loads (valves, motors, transformers, etc.) must be equipped with an overload protection (e.g. RC, diode, etc.)
- In case of harsh environment and presence of devices with an high level of interference (inverter or other), the emitting source must be shielded. Also add an external filter on the power cable, to prevent malfunctioning due to electromagnetic interferences

Installation Instructions

The following indications should be observed:

- Do not force the terminal block while clamping cables
- No cable prods are required for connecting cables to the terminals
- Use 0.5 mm² cables for wiring sensors and analog output, and 2.5 mm² cables for all the remaining connections
- Observe all rules and safety regulations for electrical installations
- Electrical and electronic work should only be performed by qualified technicians!

Installation in 4 Steps

The analyser can be mounted with or without protective housing.



Avoid direct sunlight, which can interfere with the optical reading in the analysis chamber.
Avoid strong artificial light sources, to prevent any electromagnetic interference.
Do not install under dripping pipes.

- **Step 1a: Mounting without housing**
Mount the equipment on the wall or suitable support, using 4 screws (max 6 mm). For holes position, see drawing.
- **Step 1b: Mounting with housing**
Mount the unit using the 4 supplied brackets. The supports can be rotated by 45° to 90° towards the outside. Alternatively, the unit can be installed on a plate, by fixing it with 4x M6 screws. For holes position, see drawing.
- **Step 2: Hydraulic connections**
Use a 6x4 mm flexible pipe. Install a shutoff valve on the water inlet pipe. Discharge tube should be short and inserted in a funnel or open drain (without counter-pressure).
- **Step 3: Electrical connections**
Check the required supply voltage (230V~ 50/60Hz or 24V~/~), and refer to the electrical diagrams on the next pages.



Only qualified technicians may operate wiring. All relevant rules and safety regulations must be followed.

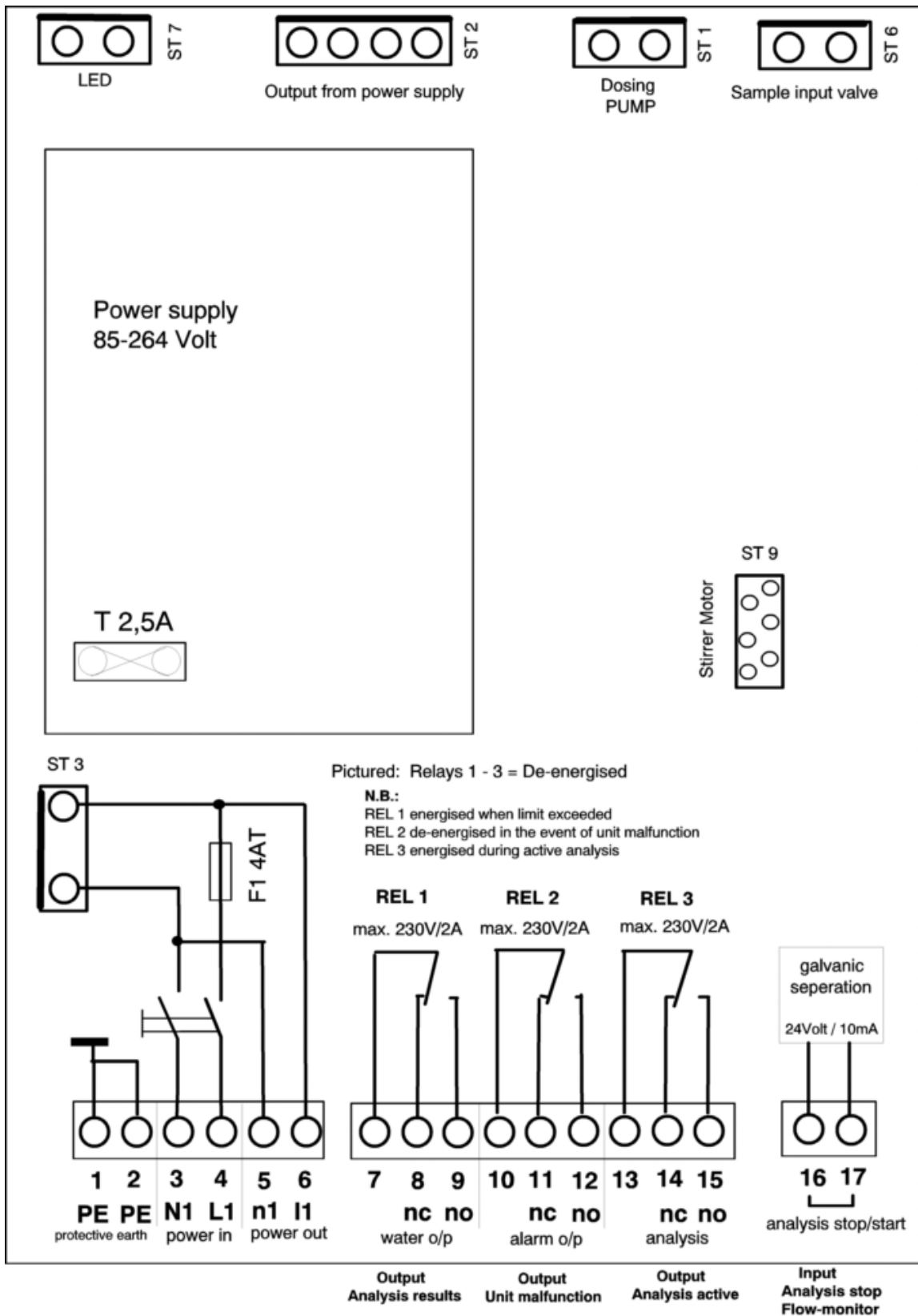

Pictured: Relays 1, 2 & 3 de-energised

Power supply primary
ST 3

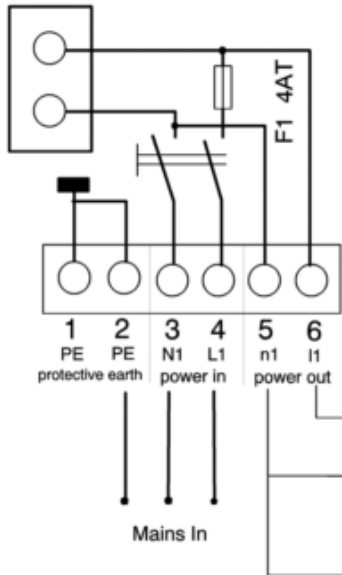

Attention:

- REL 1 energised when limit exceeded.
- REL 2 de-energised in event of unit malfunction.
- REL 3 energised when analysis active.

REL 1 max. 230V /2A REL 2 max. 230V /2A REL 3 max. 230V /2A

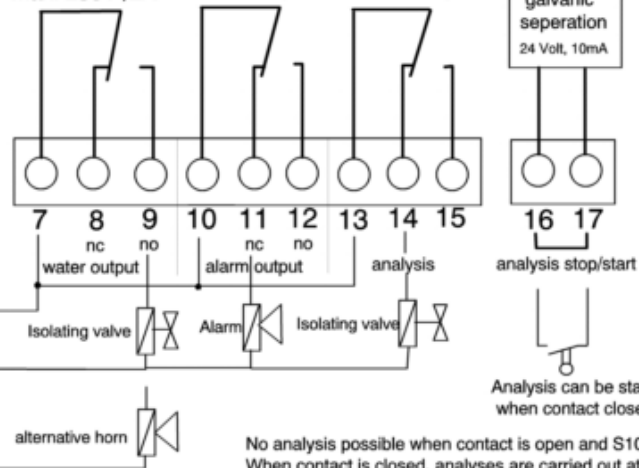

No analysis possible when contact is open and S10 is OFF:
When contact is closed, analyses are carried out at set intervals.

Option:
Parallel operation
of REL 1 und REL 2
if connecting a horn.

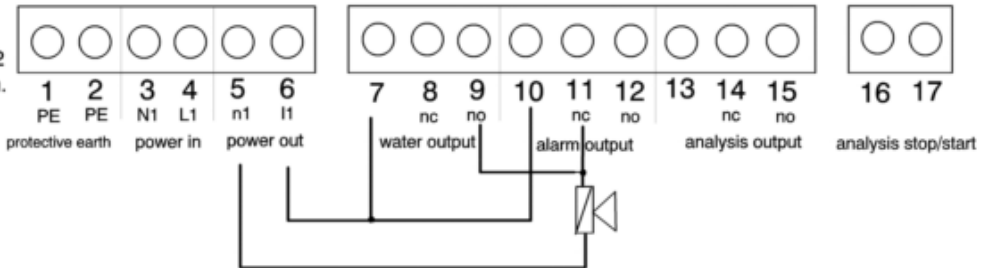

Option:
Connecting potential free
contacts for communication
with a control room or
controller: Contacts are
closed if limit exceeded
or unit malfunctions.

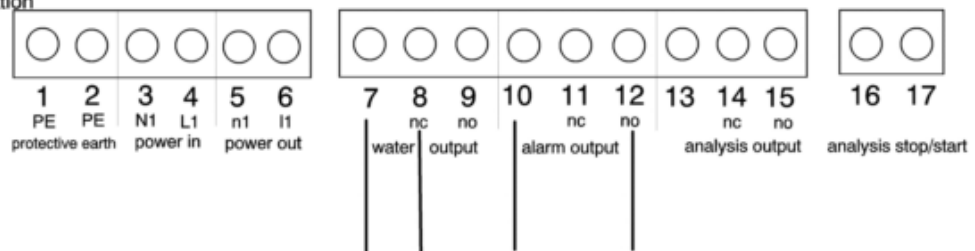

Option:
Connecting potential free
contacts for communication
with a control room or
controller: Contacts are
open if limit exceeded
or unit malfunctions.

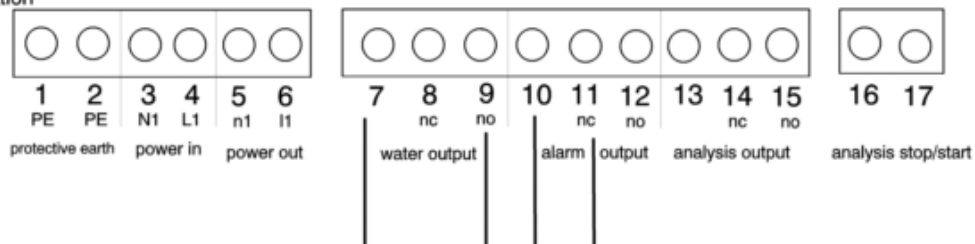

- **Step 4: Supplying the Indicator Bottle**

Open the bottle and insert the suction lance. Tighten the plastic nut to fix the lance.



The indicator is not supplied with the unit, but should be ordered according to the needed range for the specific application (see “Spare Parts and Reagents” section). Only original indicators must be used.



Health and safety.

Chemicals should be handled with care. Avoid contact with eyes, skin and clothes. Thoroughly wash hands in case of contact. Read and follows the indications provided in the MSDS. The supplier accepts no liability for dye stains or other damages due to an improper handling of the indicator. Appropriate personal protective equipment (PPE) must be used: workwear, lab gloves, eye goggles.

Wall Mounting

Installation without protective housing.

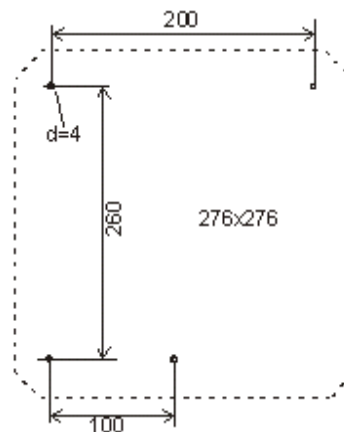

Installation with protective housing.

Note: the picture shows the unit mounted vertically, but the brackets can also be fixed 45 or 90°.

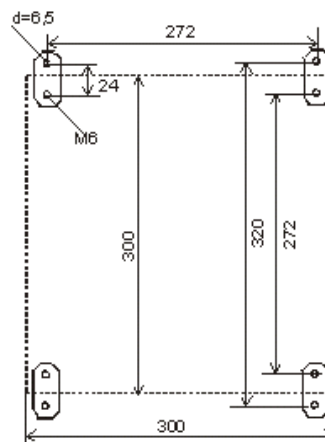

Relay Outputs

- Limit value : GOOD / BAD water → Relay REL1, terminals 7 / 8 / 9

If the limit value defined by the indicator is exceeded, an alarm signal is generated.

This signal can be used for activating an acoustic alarm, closing a solenoid valve, or starting a regeneration of the softening system. You can select to have a continuous signal (reset as soon as the analysis result falls below the limit), or a pulse signal. This choice is made through the S4 and S5 micro-switches.

Note that the S9 micro-switch reverses the limit from maximum to minimum, i.e. GOOD water below or above the indicator limit.

Available relay configurations:

1. Pulse contact → 3 seconds
2. Pulse contact → 60 seconds
3. Continuous signal → no analysis stop, i.e. the signal automatically resets when the analysis result is "GOOD water" again, and the device resumes normal operations, with the set frequency; the red LED (on the left) blinks and has to be reset manually (RESET button)
4. Continuous signal → with analysis stop, i.e. the analysis will not restart until the alarm is manually reset; the red LED (on the left) blinks and has to be reset manually (RESET button)

- Failure → Relay REL2, terminals 10 / 11 / 12

The relay REL2 is used when a malfunctioning occurs. In normal conditions, the contact is between terminals 10 and 12, while upon error or power failure, the contact is between terminals 10 and 11. The relay is triggered by:

1. Power failure → The system is off
2. Lack of indicator → The level is below the 10%
3. Zero test error → Turbid sample (check the indicator dosage), due to:
 - Dirty analysis chamber
 - Presence of air bubble in the water sample
 - Electronic malfunctioning
4. Analysis error → No colour is developed in the analysis chamber, due to:
 - Indicator is not dosed
 - Indicator is expired or contaminated
 - No water in the analysis chamber
 - No mixing (check the functioning of the magnetic stirrer)

- Analysis in progress → Relay REL3, terminals 13 / 14 / 15

This signal is generated when the analysis starts and remains active until the chamber washing cycle is completed. You can set a delay for the analysis start (opening of the solenoid valve).

Use the relay REL3 for driving:

- A cooler, to have a water sample with the right temperature
- A purge solenoid valve, to have fresh softened water
- An external pump for dosing the sample in case of lack of pressure

Only after the set delay has elapsed, the solenoid valve opens.

Connection of Remote Signal

- “IN” digital input, terminals 16 / 17

The contact is supplied with jumper, and can be configured through the S9 switch as follows:

- S9 = **OFF** “STOP” function: when the contact opens, the analyzer stops operations. It is useful for example to prevent analysis during regeneration processes or when water is not used (flow switch). This means that the analyzer operates following the set schedule and - at each analysis - checks the status of terminals 16 and 17. If there is no STOP contact, the analysis will be performed. Note that an analysis in progress is not aborted upon STOP signal.
- S9 = **ON** Function A: in case of “BAD water” result, the device repeats the analysis before generating an alarm signal.
Function B: this contact operates as START signal for an additional analysis.
Special function: if S1 and S2 = OFF, the analysis is only triggered by the START contact on terminals 16 / 17; no automatic operations, but manual activation is allowed.



Terminals 16 / 17 accept **voltage-free contact** only.
The input functions can be controlled through the diagnosis menu (step 13).
If the 16 / 17 input is not used, put S9 in OFF and insert a jumper.

START-UP AND CONFIGURATION

Summary of the System Functioning

This analyser has been designed to monitor the water hardness through colorimetric evaluation. Each dosed indicator develops a particular colour in water, and each colour allows the light passes in a different way. The wavelength of the transmitted light is detected by a photometer and, therefore, the hardness level is determined on a colorimetric basis.

Basically, the system has been developed as part of a water treatment system (e.g. softeners for boiler water).

The analyser automatically and regularly implements the process of sampling the water, injecting the indicator, stirring and evaluating the result. The analyser automatically determines a hardness leakage and gives an alarm through a voltage-free relay output. This contact can be used to trigger, for example, a regeneration of the softener.

An accurate and reliable method of measurement definitely replaces the time-critical, and inaccurate manual analysis or the analysis through indirect methods.

With external alarm output, fault-diagnostic function as well as the stop (by remote signal input) of monitoring while the water softener is in regeneration or the water feed is stopped, the analyser provides a useful functionality.

The limit for water quality to be monitored is defined by the indicator used. The following limit indicators are offered:

Limit Value	1 mg/l	2 mg/l	4 mg/l	6 mg/l	10 mg/l	20 mg/l	40 mg/l	60 mg/l	100 mg/l	200 mg/l
Residual Hardness °dH	0.05	0.1	0.2	0.3	0.5	1	2	3	5	10
Type	500/500	501/500	502/500	503/500	505/500	510/500	520/500	530/500	550/500	600/500
Carbonate Hardness °dH	1	1.5	2	3						
Type	C710/500	C715/500	C720/500	C730/500						

Before Starting Operation

Before starting the system, please perform the following checks:

- secure wall installation
- correct wiring (if necessary, consult an electrician)
- hydraulic connections (check that water inlet and outlet lines have not been reversed)
- working pressure does not exceed the maximum allowed value (if necessary, install a pressure reducer)
- water quality fulfils the required characteristics (see “Technical Data” section; if necessary install a pre-filter)
- the indicator bottle is in place and correctly connected, with no leakages
- the indicator range is the required one for the specific application (check alarm limit value)
- the indicator is not expired or contaminated
- all parts and accessories of the analysis chamber have been correctly mounted
- the dosing tube is connected

- the water treatment system is working and water sample is supplied / analysed
- the relay operations have been correctly configured
- for any additional information or technical details, please contact the manufacturer

Configuration Switches

The analyser is equipped with 3 configuration switches:

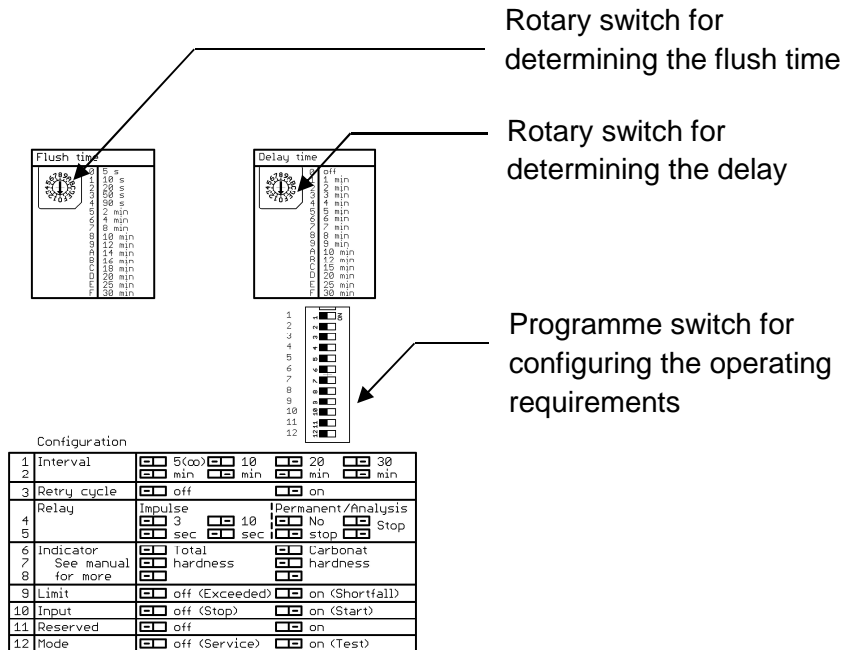

Configuration and Settings



Switch off the unit and open the lid.

WARNING! Check the power supply voltage on the unit label (230 V~ 50/60Hz or 24 V~/-)

The DIP switches S1 ... S12 are located on the back side of the display board. The display board is screwed to the unit lid and should not be removed. The two 16-position rotary switches are also located on the same side of the board, and are used for setting the flush time and the delay time.

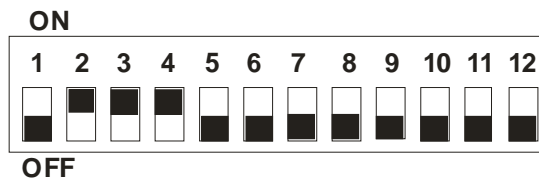

Factory Settings		Switch Configuration		
Flush time	4 minutes	Position 6	4 min.	
Delay time	Off	Position 0	0 min.	
Analysis interval	10 minutes	S1 OFF	S2 ON	
Analysis repetition upon "BAD water" result	Yes	S3 ON		
Relay 1 configuration	Contact closed = continuous analysis	S4 ON	S5 OFF	
Parameter to be tested	Total hardness	S6 OFF	S7 OFF	S8 OFF
Monitoring type	Signal upon limit exceeded	S9 OFF		
IN input configuration	Flowmeter	S10 OFF		
Operation mode	Analysis	S11 OFF	S12 OFF	



Only qualified technicians may operate wiring! All relevant rules and safety regulations must be followed.

WARNING! Power supply voltage: 230 V~ 50/60Hz or 24 V~/ (check label)



For operating the rotary switches and for setting the slide switch, use a small insulated screwdriver.

Use only good quality tools, to avoid any damage to sensitive components.

• FLUSH TIME

The pre-analysis flush time is set using the left hand rotary switch "Flush time", from 5 seconds to 30 minutes (see below table)

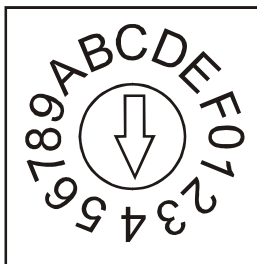

Position	Time	Position	Time
0	5 sec.	8	10 min.
1	10 sec.	9	12 min.
2	20 sec.	A	14 min.
3	50 sec.	B	16 min.
4	90 sec.	C	18 min.
5	2 min.	D	20 min.
6	4 min.	E	25 min.
7	8 min.	F	30 min.

The flush time should be calculated according to the length of the water supply pipe, knowing that:

- 1 meter of pipe with ID 4 mm, contains approx. 13 ml of water
 - doubling the diameter results in a fourfold volume (ID 8 mm → approx. 50 ml/m)
 - the flow rate is influenced by the internal diameter of the inlet valve and the water pressure
- For example, 5 meters of 6x4 pipe (ID = 4 mm) contain approx. 63 ml of water and, depending on the pressure, will be flushed in approximately 4 seconds.

Note that the operating conditions may vary significantly from the theoretical calculation, due to pressure fluctuations and different flow rates at different pipe diameters. Consider all installation variables and set the flush time accordingly, in order to always analyse fresh softened samples.

A minimum flush time of 20 seconds is recommended.

• **DELAY TIME**

The time delay prior to taking a sample is set using the right hand rotary switch “Delay time“, from 0 seconds to 30 minutes (see below table).

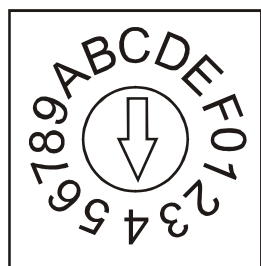

Position	Time	Position	Time
0	0 min.	8	8 min.
1	1 min.	9	9 min.
2	2 min.	A	10 min.
3	3 min.	B	12 min.
4	4 min.	C	18 min.
5	5 min.	D	20 min.
6	6 min.	E	25 min.
7	7 min.	F	30 min.

Set a delay time which ensures that no hot water will enter into the analysis chamber.

- The maximum allowed temperature of the water sample is 40°C.
If there is a long time interval between analyses, it is not convenient continuously cool the water to be tested. Connect rather a solenoid valve that controls the cooling water flow to cool the sample. When the sample temperature is under 40°C, the water can be analysed.
- The delay time allows this cooling process before starting the analysis, and must be calculated on site, because it is affected by several factors, as water temperature, pressure, flow rate, etc. Test the system for correct adjustment.

• **ANALYSIS INTERVAL**

There are four fixed interval times selectable by varying the positions of switches S1 and S2. The analysis interval determines the frequency of sampling and measurement.

The interval starts at the opening of the analyser solenoid valve and lasts until the next opening (with the exception of a possible delay time).

- When the “IN1” digital input is open, the analysis start is disabled. The unit is delivered with a jumper that closes terminals 16 / 17. Check that this jumper is in place or, alternatively, connect an external switch (e.g. flow switch).
- The “IN1” contact can be inverted through the S10 microcontroller, from STOP signal (S10=OFF) to START signal (S10=ON) with interval of 10, 20 or 30 minutes.
If S1 and S2 are OFF, no automatic analysis can take place.

Attention! If the ‘IN’ input remains bridged, continuous analyses will be performed.

Analysis interval		
S1	S2	time
OFF	OFF	5(∞)* min.
OFF	ON	10 min.
ON	OFF	20 min.
ON	ON	30 min.

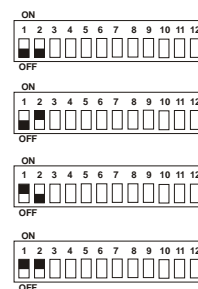

(∞)*S1=OFF, S2=OFF and S10=ON

No timed analysis (only volumetric analysis or triggered by an external signal)

• ANALYSIS REPETITION UPON “BAD WATER” RESULT

An analysis with “BAD water” result can be repeated. Only after two subsequent “BAD water” results, the relay REL1 is activated. The second analysis is performed after 4 minutes (this interval is factory configured and cannot be modified).

In this case the analyzer does not control if a STOP contact is present, therefore, the second analysis is always performed.

Analysis repetition in case of “BAD water” result	
S3	Functioning (= REL1 activation)
OFF	Alarm in case of “BAD water” result
ON	Alarm in case of a second “BAD water” result

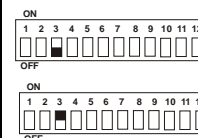

• RELAY 1 CONFIGURATION

The relay REL1 signals that the hardness limit has been exceeded. The contact can be configured as pulse contact (3 and 60 seconds) or continuous contact.

When the limit is exceeded, the continuous contact can be configured for operating in two different modes, as follows:

1. The analyser keeps operating, and the relay REL1 deactivates when the reading is below the limit.
2. No further analyses is performed and the relay REL1 needs to be deactivated manually (RESET) for resuming to normal operations.

Functioning of relay REL1		
S4	S5	Functioning
OFF	OFF	Pulse contact, 3 seconds
OFF	ON	Pulse contact, 60 seconds
ON	OFF	Continuous contact, no analysis stop
ON	ON	Continuous contact and analysis stop

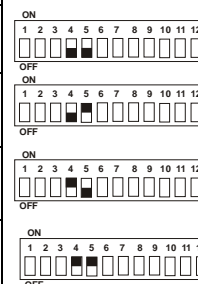

• **PARAMETER TO BE MEASURED**

The analyser can be used to monitor different parameters. The parameter analysed and relevant limit are determined by the reagent used and by the position of S6 / S7 / S8 (see below table).

Parameter to be tested			
S6	S7	S8	Parameter
OFF	OFF	OFF	Total hardness
OFF	OFF	ON	Carbonate hardness
OFF	ON	OFF	minus M-value
OFF	ON	ON	plus M-value

• **MONITORING TYPE**

Monitoring of the correct functioning of a water softener (= **total hardness**). The analyser can check if water hardness is above or below the set limit.

→ **Threshold to be monitored = maximum limit**

- Water is not good if the hardness value is above the indicator limit
- S9 micro-switch = OFF
- Application: monitoring the correct operation of a softener, protection of RO systems

→ **Threshold to be monitored = minimum limit**

- Water is not good if the hardness value is below the indicator limit
- S9 micro-switch = ON
- Application: monitoring potable water, in which the hardness should not fall below a certain limit

→ The above descriptions refer to the monitoring of the maximum limit

Limit monitoring	
S9	Functioning
OFF	Alarm in case of max limit exceeded
ON	Alarm in case of hardness below min limit

- **“IN” INPUT CONFIGURATION**

The “IN” input can be configured for working in two different ways:

1. STOP

If no analysis is required, set S10=OFF.

For example in case of contact from a flow meter, level sensor (tank full), pressure switch (low water pressure), or regeneration of a single-filter water softener.

Note that:

- this input accepts voltage-free contact only
- the analyzer is supplied with this input bridged, for operating according to the set analysis schedule

2. START

a) Analysis interval: 10, 20 or 30 minutes

This mode is useful for performing more analyses, in addition to the scheduled ones

b) If **S1=OFF and S2=OFF**, analysis can be performed **only** if the IN1 contact is configured for **START**

Note that:

- this input accepts voltage-free contact only
- if the IN1 contact is bridged, continuous analyses are performed

“IN” Configuration	
S10	Working mode
OFF	STOP: Analysis stops when contact is open
ON	START: Analysis starts when contact is closed

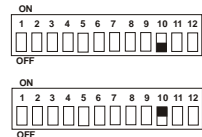

Start-up in 5 Steps

Check that the analyzer has been correctly installed and configured, then proceed as follows:

STEP 1

Switching ON the device

- Power the device
- The green LED (ANALYSIS RESULT) blinks

GREEN light



STEP 2

Confirming the indicator supplying

- Press simultaneously the INDICATOR and RESET keys



Warning! Confirm the supplying only if the indicator bottle is full



STEP 3

Filling the analysis chamber with water

- Press the FLUSH key until the analysis chamber is completely fill with water and **check that no air bubble is present**



STEP 4

Bleeding the dosing pump

- Press the INDICATOR key until the indicator enters in the analysis chamber
- After a set time, the magnet stirs for mixing the indicator with water



STEP 5

Starting the analysis

- Press the START key to perform the first analysis
- The analysis begins with a washing of the chamber (a delay time may be set)

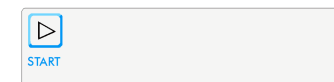

LED Indicators

Analysis result

A two-colour LED gives information about the analysis result

1. **GREEN light, blinking:**
no result available; no analysis performed yet
2. **GREEN light, steady:**
“GOOD water” indication (hardness below the limit value)
3. **RED light, steady:**
“BAD water” signal (hardness above the limit value). The relay REL1 has not been triggered yet (configuration: alarm upon second BAD result).
4. **RED light, blinking:**
“BAD water” signal (hardness above the limit value). The relay REL1 is activated.

GREEN light



RED light



Analysis in progress

1. **YELLOW light, steady:**
the analysis has started
- 2a. **YELLOW light, blinking:**
the analyzer is not working: a timed analysis should start but there is a STOP contact on the IN1 input. Only after removing the STOP signal, the analyzer starts operations.
- 2b. **YELLOW light, blinking ; RED light, steady or blinking:**
the analyzer is not working: no analysis is performed after the limit hardness has been exceeded
- 2c. **YELLOW light, quickly blinking:**
the analysis is delayed by a set time

YELLOW light



RED and YELLOW lights



Indicator lack

1. **BLUE light, steady:**
residual indicator < 30%
2. **BLUE light, blinking:**
residual indicator < 10%, and alarm relay REL2 is active

BLUE light



Hardness alarm

1. **RED light + RED light, blinking:**
analysis result (blinking RED) + alarm (blinking RED) → max limit exceeded
→ the relay REL1 is active
2. **RED light, blinking + RED light, steady:**
analysis result (blinking RED) + alarm (steady RED) → max limit exceeded
→ the relay REL1 is not active because it has been manually reset, or the pulse signal is finished

RED and RED lights



Indicator lack alarm

1. **BLUE light + RED light, blinking:**
Indicator level < 10% (blinking BLUE) + alarm (blinking RED) → lack of indicator
→ the relay REL2 is active
2. **BLUE light, blinking + RED light, steady:**
Indicator level < 10% (blinking BLUE) + alarm (steady RED) → lack of indicator
→ the relay REL2 is not active because it has been manually reset

BLUE and RED lights



Failure

1. **RED light, blinking:**
measurement error or system failure
- zero test (transparency) failed
- measurement error, no other LED lights on
→ the relay REL2 is active
2. **RED light, steady:**
measurement error or system failure
- zero test (transparency) failed
- measurement error, no other LED lights on
→ the relay REL2 is not active because it has been manually reset

RED light



Manual Operation

START



Analysis Start

- Analysis can be started manually
- An analysis in progress can be aborted by jumping on the next analysis step
- Press this button for resetting relays REL1 and REL2



Washing (FLUSH)



Washing and filling the analysis chamber

- The analysis chamber can be cleaned without starting the analysis



INDICATOR



Venting the dosing pump / dosing the indicator

- Dosing pump and suction tubes can be vented for example at start-up or after maintenance; at the same time the indicator can be dosed for monitoring the reaction (green / red).
- When the pump works, the magnet stirs



RESET



Reset of the alarm signals

- Reset of the relay REL1 (hardness exceeded)
Also see "Test Result" section
- Reset of the relay REL2 (interference, failure or lack of indicator)
Also see the "LED Indicators" section
- An analysis in progress can be aborted



Indicator supply

- To confirm the indicator supply, press the INDICATOR and RESET buttons simultaneously. The blue LED (lack of indicator) and the red LED (alarm) light up. This indication ensures that the counter of indicator consumption has been reset.

Warning! Perform this reset only if a 500 ml full bottle of indicator is provided.



MAINTENANCE AND SERVICE

In order to ensure a long and reliable functioning of the analysis unit, maintenance should be carried out at regular intervals. Before starting any maintenance operation, please ensure that the unit is switched off. During maintenance, no analysis will be carried out. Always wear protective glasses and gloves to avoid contact with reagent or cleaning fluid.

The following maintenance schedule is recommended:

All 6 months	Clean the measuring chamber (in case of high environmental or water temperatures or high levels of biocides, it may be necessary to reduce the interval)
6 to 12 months	Installation maintenance set

Cleaning the Measuring Chamber

Cleaning the measuring chamber requires about 20 minutes. Proceed as follows:

- Remove the dosing pump from its installation by squeezing the clips above and below, then pulling outwards
- Remove the connections to the dosing plug and reagent bottle
- Pull the securing pins outwards until all the plugs are free; do not try to remove the pins completely
- Remove the chamber from the holding pins on the control box
- Clean the chamber using the cleaning kit (part code 200013 or 200013S) according to the instructions

When re-assembling, please proceed as follows:

- Push the clean chamber on to the two holding pins and push in the securing pins to secure
- Re-insert all plugs and secure with securing pins; ensure that the plugs are firmly pushed in to their holes before attempting to push in the securing pins. **Do not force them!** This may lead to damage of the plugs or pins. All pipes must be free and not twisted.
- Switch the unit on again, flush the measuring chamber then pump reagent into the chamber; the unit is now ready for use (Menu > Manual > Flush / Reagent)

Changing the Dosing Pump Head

It is necessary to change the dosing pump head at regular intervals. This is included in the "maintenance set for professional analyzer". This operation takes about 10 minutes.

Please proceed as follows:

- Switch off the unit
- Remove all connections to the dosing plug and reagent bottle
- Remove the pump from its installation by squeezing the clips above and below then pulling outwards
- Remove the dosing plug at the top of the chamber by pulling the 2 securing pins and gently pulling the plug upwards
- Discard head and tubes

When re-assembling, please proceed as follows:

- Connect the head to the reagent bottle; turn the bottle until all bends are removed and the pipe hangs freely
- Connect the pump to the dosing-plug. First ensure that the pipe is not twisted then re-insert the plug. Ensure that the plug is firmly pushed in to its hole before attempting to push in the securing pins. **Do not force them!** If you have difficulty inserting the plug without force, apply a little Vaseline to the O-ring.
- Clip the head securely on the pump
- Switch the unit back on, flush and pump reagent into the chamber. The unit is now ready for use (Menu > Manual > Flush /Reagent).

Changing the Reagent Bottle

Ensure that the new reagent is within its best before date. Only use fresh reagent.

Please proceed as follows:

- Switch off the unit
- Unscrew the cap and remove the bottle adapter and lance. Insert these in the new bottle and secure cap. Clean up any spilt fluid.
- Switch the unit back on, flush and pump reagent into the chamber. By confirming the reagent bottle change after the injection of reagent, the reagent level for the 'BOB' operation will be reset to 100%. Only use 500 ml bottles.

Calibrating the unit

The unit is calibrated at the factory at a room temperature of 20°C. If the unit is to be used in especially hot or cold environments, please re-calibrated when commissioning.

ERRORS

Fault Finding

- **The analysis will not begin**

Check that the flow meter is correctly configured and connected.

Check that the interval time is set.

Check whether a water meter is connected and correctly configured.

Check, if relevant, connections from an external controller.

- **Error during the blank test**

Check that there is water in the chamber and that the supply and waste pipes are not swapped.

Check the chamber for dirt, gas bubbles or foreign bodies.

Check the water pressure (recommended 1-2 bar).

Check that the waste pipe is free and that there are no foreign bodies in the magnet valve.

If a pump is used to supply the sample water, ensure that it is correctly connected.

With the help of the diagnosis menu, check the function sensor and magnet valve.

- **Error during titration**

Check that there is enough reagent available.

Check the pipes between the reagent bottle and the dosing-pump for air bubbles. If necessary, pump reagent until the pipes are full of reagent.

Check that the blue O-ring is still on the nozzle of the dosing-plug.

Check that there is water in the chamber.

Check that there is a magnetic stirrer (stir-fish) in the chamber.

Check the reagent delivery, the sensor and the stir-fish with the diagnosis menu.

- **False test result**

Check that the reagent corresponds to that programmed.

Check for air bubbles in the reagent delivery pipe.

During the blank test, check that the sample water is not coloured by foreign substances, sediment or air bubbles.

Check that there is water in the chamber and that the supply and waste pipes are not swapped.

Check that there is a magnetic stirrer (stir-fish) in the chamber.

Check that the blue o-ring is still on the nozzle of the dosing-plug and that it is positioned correctly.

Check that the magnet valve closes properly.

Exchange the reagent pump-cassette

Re-calibrate the unit with a new correction factor.

Diagnosis Function

If the analysis unit doesn't function properly, you have the possibility to check all the functions. Please take in to consideration any controllers and peripherals that are connected. Observe all safety regulations.

Select Menu > Manual>Diagnosis. You can check every part step for step:

- **Display**

The display changes its color between red, green and blue.

- **Sensor**

The LED in the chamber pulses on and off. If this doesn't happen, check the electrical connections to the LED-plug and in the unit. If everything is ok, the LED plug must be replaced.

- **Solenoid valve**

The magnet valve in the water inlet can be heard opening and closing. If this is not the case, check the electrical connections to the valve and inside the unit. If all connections are okay, measure the voltage at the valve while the test is in progress. It should switch between 0V and 20V. When this is okay then an electrical error can be ruled out. Change the magnet valve.

- **Reagent dosing**

When the diagnosis starts, the dosing pump can be seen to turn. It can also be heard. If this is not the case, check the 4 pole connector on the circuit board. If you can hear the motor but there is no movement, then the pump-cassette is defect. If the connection are okay and the pump can neither be seen or heard, then the pump is defect or there is a defect in the electronics.

- **Magnetic stirrer**

The stirrer in the measurement chamber should spin - at first slowly – then increasing to its maximum speed. If the stirrer doesn't spin, check the connection to the circuit board (red plug). Remove the chamber and check that nothing is obstructing the movement of the drive disk. If the above are okay, change the motor assembly.

- **Relay 1 to 4**

When this function is selected, you should hear the relays clicking as they operate. Using a continuity meter or buzzer, measure between COM and A then COM and B. If there is no continuity when the relay contacts close or there is no sound of clicking, the control circuit board must be changed.

- **Current loop**

To test the current loop, a test meter set to mA is necessary. Connect the meter probes to the connector marked [20mA+ und 20mA-].

SPARE PARTS AND REAGENTS

Code	Description
111 002	Magnetic stirrer
111 008	Bottle connector
111 009	Bottle adapter
111 011	Suction lance
111 060	Bottle cap
111 013	Inlet pipe ¼"
111 014	Magnet valve 24V complete
111 015	Outlet pipe 6mm
111 016	Connector 6mm water outlet
111 029	Connector 6mm water inlet
111 727	Actuator for magnetic stirrer 12V complete.
111 210	O-Ring
111 217	O-Ring
111 218	O-Ring
111 000	Dosing-pump cassette
111 700	Complete measuring chamber 33-090002, 33-090701, 33-090711, 33-090712, 33-090713, 33-090716 + O-rings
111 701	Body of measuring-chamber
111 711	Inlet plug 6mm
111 712	Outlet plug 6mm
111 713	Actuator plug (LED)
111 716	Dosing plug

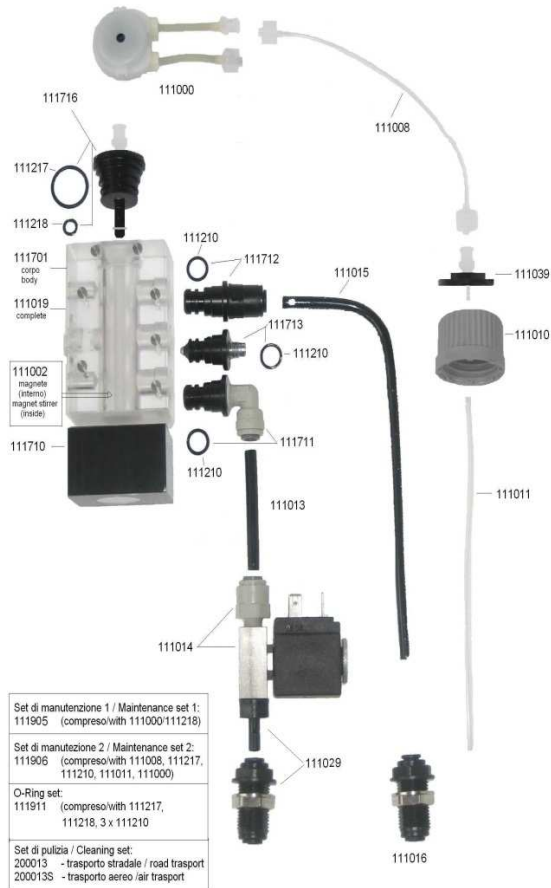

111911	O-Ring set
1x 111217	O-Ring
3x 111210	O-Ring 9 x 1,5
1x 111218	O-Ring

Spare parts (not shown in picture)	
111 020	Cable for magnet valve
111 021	Cable for Actuator (LED)
111 023	Power supply board (85-264 V)
	Control box case (with lid)
111 028	Complete dosing pump
	Complete control board
	Complete display board

Spare parts for 2-3 years	
1x 111727	Actuator for magnetic stirrer
1x 111014	Magnet valve 24V
1x 111700	Complete measuring chamber
1x 111028	Complete dosing pump
4x 111906	Maintenance set 02

111906	Maintenance set 02:
1x 111000	Dosing pump cassette
1x 111008	Bottle connector
1x 111011	Suction lance
1x 111217	O-Ring
3x 111210	O-Ring
1x 111218	O-Ring

Measurement range of our reagents

Reagents for water hardness analysis (500 ml bottles)

Code	Type	Measurement Range	
		ƒ	đH
200852	500S/500	0,04-0,21ƒ	0,02-0,12đH
200855	500/500	0,04 - 0,36ƒ	0,02-0,2 đH
200860	501/500	0,05-0,54ƒ	0,03-0,3đH
200862	502/500	0,11-1,07ƒ	0,06-0,6đH
200863	503/500	0,16-1,61ƒ	0,09-0,9đH
200865	505/500	0,27-2,68ƒ	0,15-1,5đH
200870	510/500	0,54-5,36ƒ	0,3-3,0đH
200875	520/500	1,07-10,71 ƒ	0,6-6,0đH
200876	530/500	1,61-16,07ƒ	0,9 - 9,0đH
200878	550/500	2,68-26,79ƒ	1,5-15đH
200880	600/500	5,36-53,57ƒ	3,0-30đH
Carbonate hardness			
200887	C-710/500	0,54-5,36ƒ	0,3-3,0đH
200889	C-715/500	0,80-8,04ƒ	0,45-4,5đH
200890	C-720/500	1,07-10,71ƒ	0,6-6,0đH
200891	C-730/500	1,61-16,07ƒ	0,9-9,0đH

ANNEX 1: CALCULATION TABLE FOR WATER HARDNESS

		°dH	°e	°f	ppm	mval/l	mmol/l
German Hardness	1 °dH =	1	1.253	1.78	17.8	0.357	0.1783
English Hardness	1 °e =	0.798	1	1.43	14.3	0.285	0.142
French Hardness	1 °fH =	0.56	0.702	1	10	0.2	0.1
ppm CaCO₃ (USA)	1 ppm =	0.056	0.07	0.1	1	0.02	0.01
mval/l Earth alkali	1 mval/l =	2.8	3.51	5	50	1	0.5
mmol/l Earth alkali	1 mmol/l =	5.6	7.02	10	100	2	1

ANNEX 2: INSTRUCTIONS FOR DISPOSAL

- Do not dispose the unit in domestic waste
- The unit should be taken to a certified collection point for the disposal of electrical devices
- The battery must be disposed separately
- The unit can also be returned to the dealer or manufacturer for proper disposal