



# Intelligent medical waste disinfection treatment equipment

High Efficiency, Environmental Protection, Energy Saving



Qingdao **Haier** Biomedical Co.,Ltd.

No.280 Feng Yuan Road, High-tech Zone,

Qingdao, 266109, P.R. China

Tel: +86-0532-88935593

Website: [www.haiermedical.com](http://www.haiermedical.com)



Haier Biomedical  
Biomedical



Haier Biomedical  
Haier Biomedical



@haiermedicalint  
International



International  
International



Haier  
International

## Background

With the rapid economic development, medical care has made great progress, but as a result, many problems have arisen, such as medical waste disposal. Waste gases, wastes and wastes that are not strictly sterilized can cause a variety of hazards to the ecological environment and life safety.

For this reason, various countries around the world are now actively dealing with medical waste to make it harmless. The current mainstream is based on high-temperature incineration, high-temperature steam sterilization, chemical disinfection, microwave disinfection and other methods. Multiple technologies are integrated.

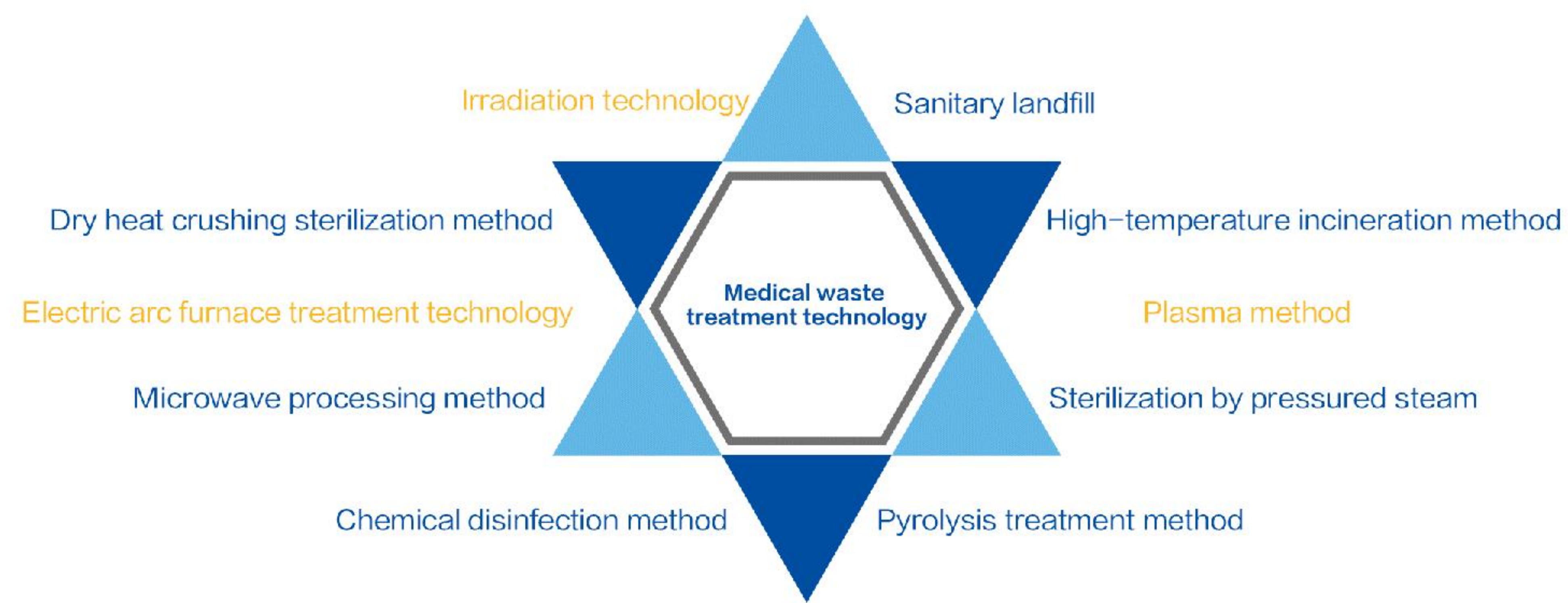

### High-temperature incineration

- ◆ Advantage: capacity reduction, thorough treatment, power generation
- ◆ Disadvantages: environmental protection, cost, energy consumption

### Pressure steam

- ◆ Advantage: low cost, good disinfection, wide range
- ◆ Disadvantages: waste gas, waste liquid, malodorous gas

### Microwave disinfection

- ◆ Advantage: low operating cost, good disinfection effect, no pollution
- ◆ Disadvantages: Single unit processing is limited

## Product introduction

HLM medical waste sterilization treatment equipment mainly adopts the principle of microwave technology, through the combined effect of microwave thermal and non-thermal effect, rapid sterilization. HLM medical waste treatment equipment is divided into the following parts according to different scenarios of users.  
Main treatment objects: infectious waste, injurious waste, pathological waste.

### Clinic Model (Section)

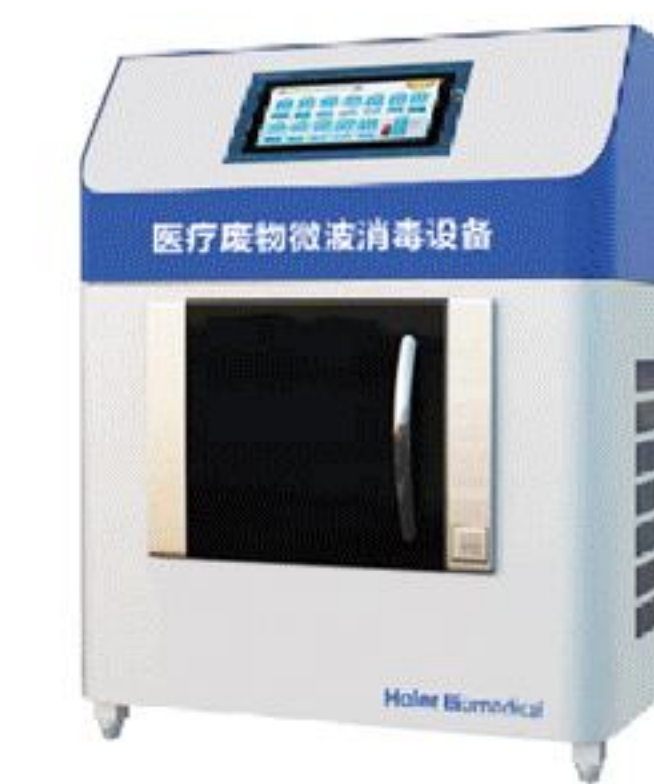

YFXDG10

- Daily processing capacity: 0-10kg
- Once treatment volume: 7-100L
- Once disinfection time: 45min
- Main function: Microwave

### Medium-sized Hospital



YFXDG100-500

- Daily processing capacity: 100-500kg
- Once treatment volume: 100-660L
- Once disinfection time: 45min
- Main function: microwave + crushing

### Large hospitals/medical waste treatment centers



YFXDG1000~10000

- Daily processing capacity: 1t-10t
- Once disinfection time: 45min
- Processing method: continuous
- Main function: microwave + crushing

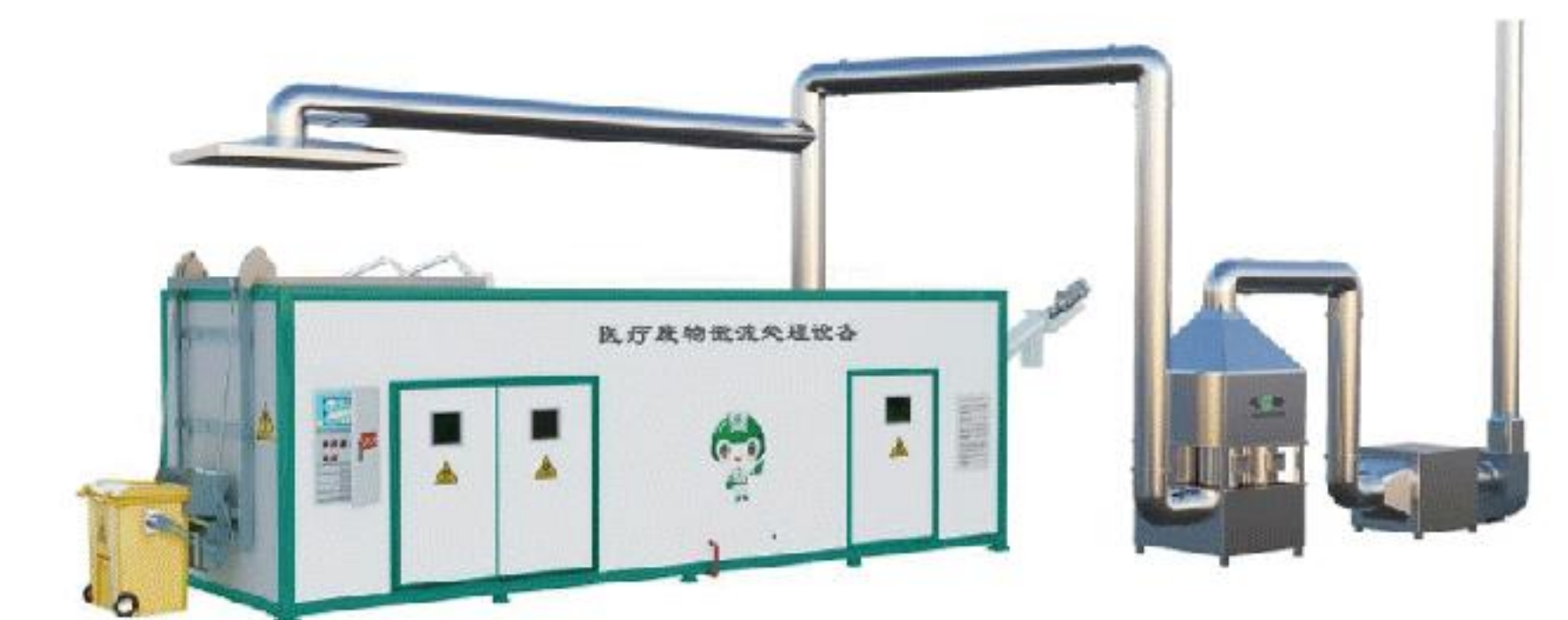

YFXDC1000~10000

- Daily processing capacity: 1t-10t
- Once disinfection time: 45min
- Processing method: continuous
- Main function: microwave + crushing



## Product advantages (medical waste sterilization vehicle as an example)



- energy saving : short disinfection time, uniform temperature rise, energy saving;
- thorough disinfection: no selective destruction of structures for all organisms, complete disinfection;
- one-person operation: high degree of automation, one person can complete all operations;
- environmentally friendly and green: no waste gas and waste water;
- resource sharing: to meet their own medical waste treatment while sharing the remaining daily treatment capacity;
- mobile and flexible: vehicle-mounted rain or shine, flexible mobile.

## Product Composition

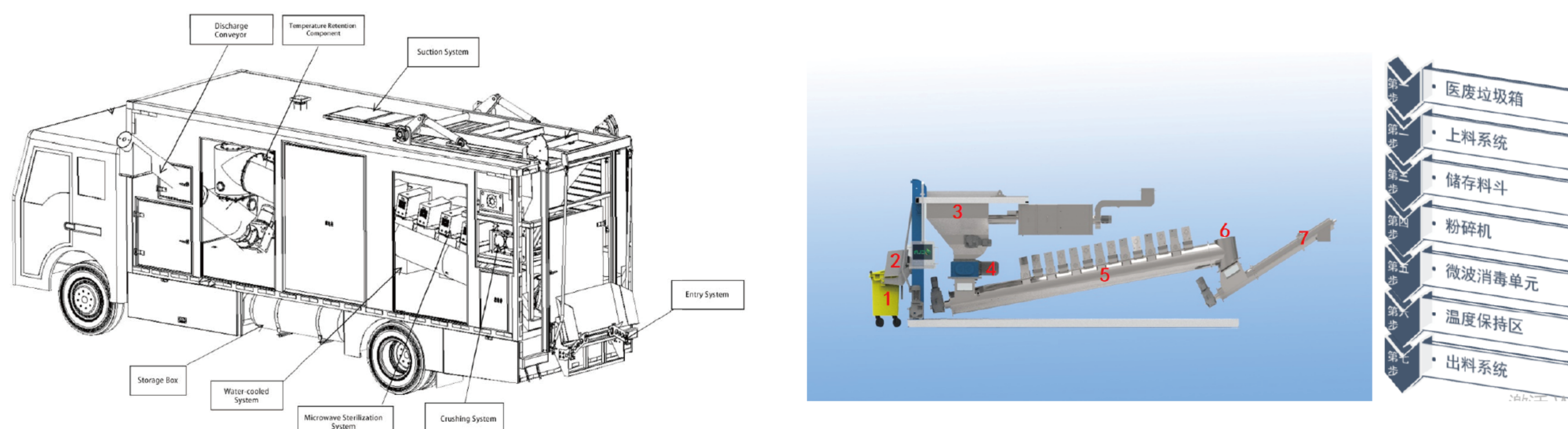

## Product Operation Logic

### Discharge system

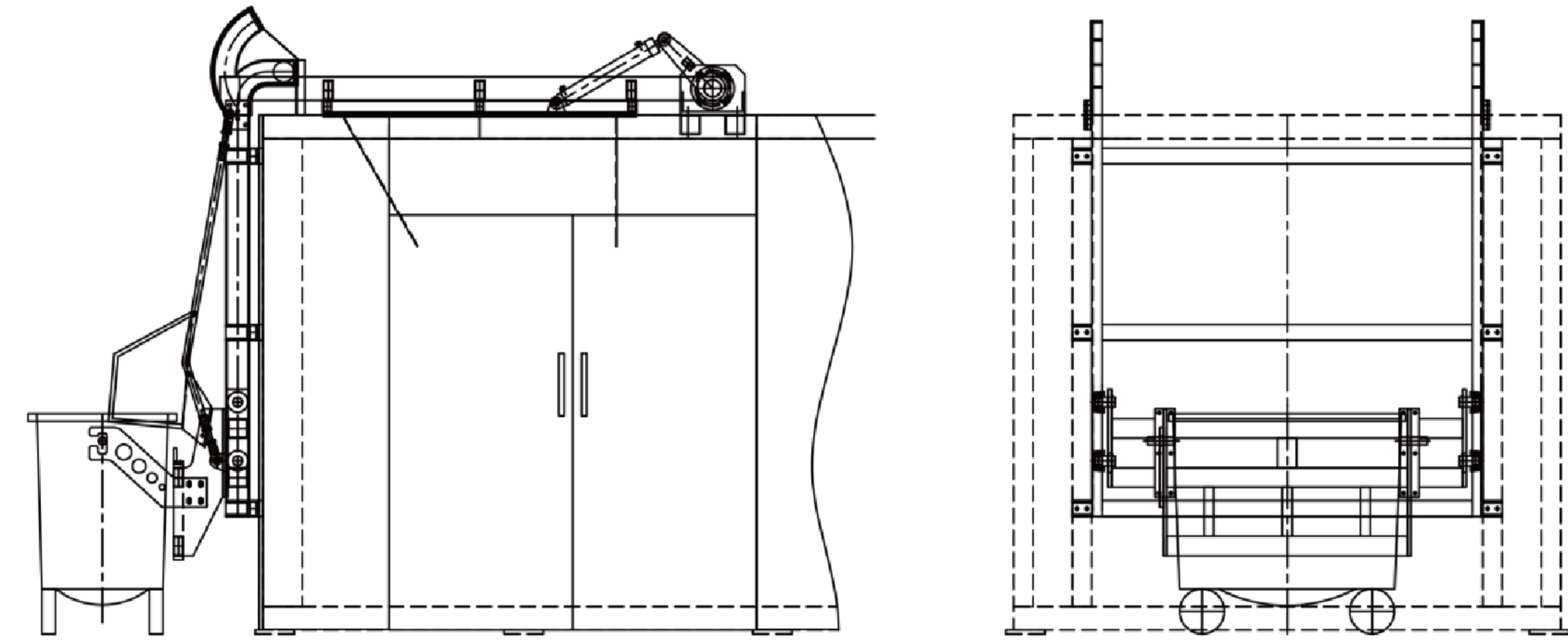

### Composition

Standard bin, hydraulic lifting device, in-place inspection device, stainless steel sealing cover, pressure material reducer and feeder arm, stainless steel sealed storage funnel.

### Function

The medical waste is loaded into the staging hopper via the bin and hydraulic lifting device. And feeds the crushing system by squeezing the medical waste through the feeder arm.

### Operation

The equipment is loaded to the temporary storage hopper through the lifting device that can mount the standard bin with medical waste. When the temporary storage hopper is opened, the negative pressure protection is activated inside the hopper to prevent the odor and steam from spreading to the working environment, and then the flip cover of the temporary storage hopper is closed and sealed after the lifting device has poured the medical waste into the hopper.

### Crushing systems

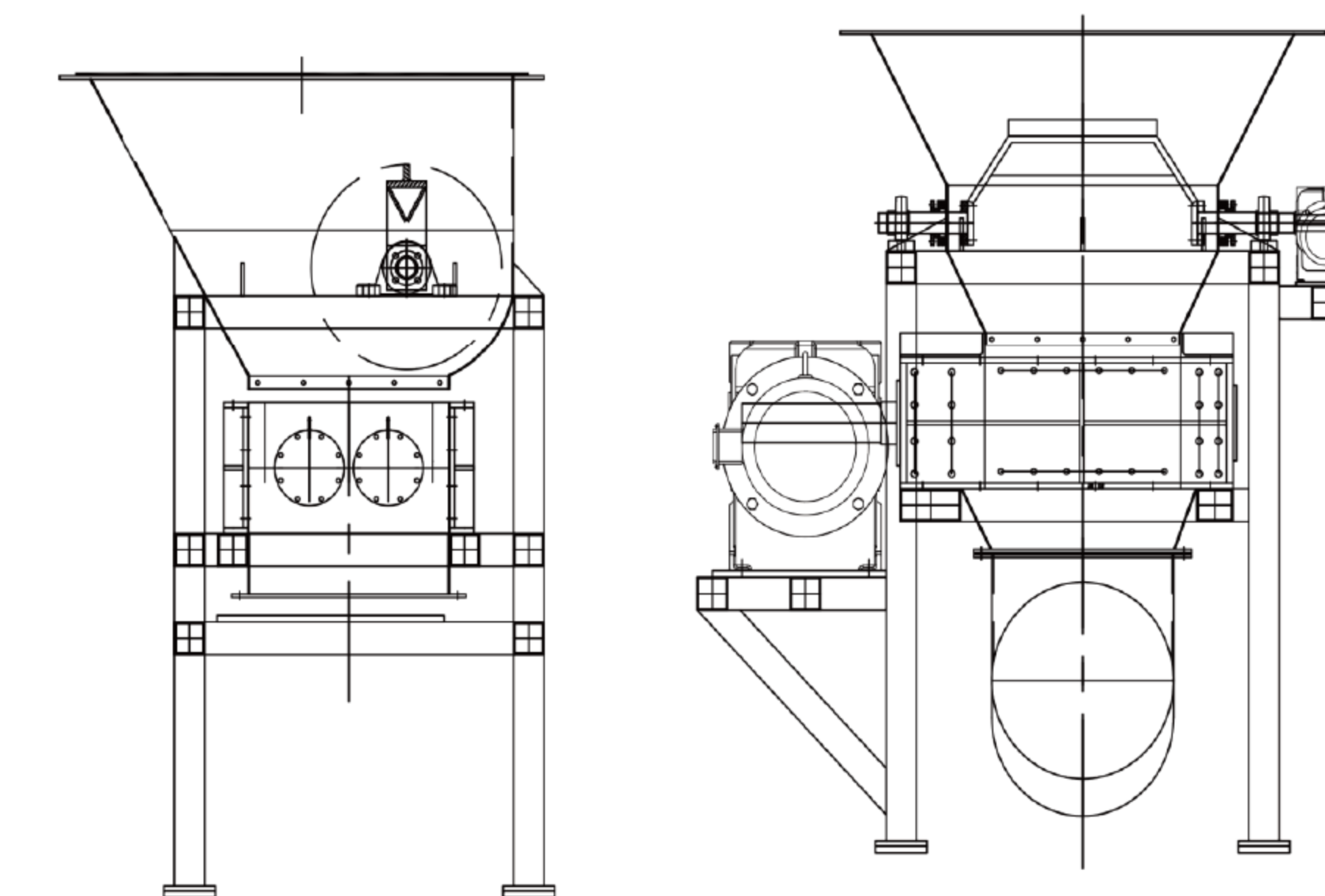

## Product Operation Logic

### Composition

Composed of box, transmission device, crushing tool, screen, motor and reducer;

### Function

The crusher is used to crush the medical waste in the storage hopper, also known as disfigurement.

### Operation

The scrap is fed from the staging hopper by the feeder arm and the scrap is crushed to a particle size that is easily conveyed and effectively sterilized; the crushing system consists of a rectangular knife box, gear box, dual knife tool shafts and a reduction motor that drives the knife shafts in opposite rotational directions through a spur gear. The cross-edge of the blade tip on one shaft engages the spacer ring during operation to cut the scrap.

#### ▶ Microwave sterilization system

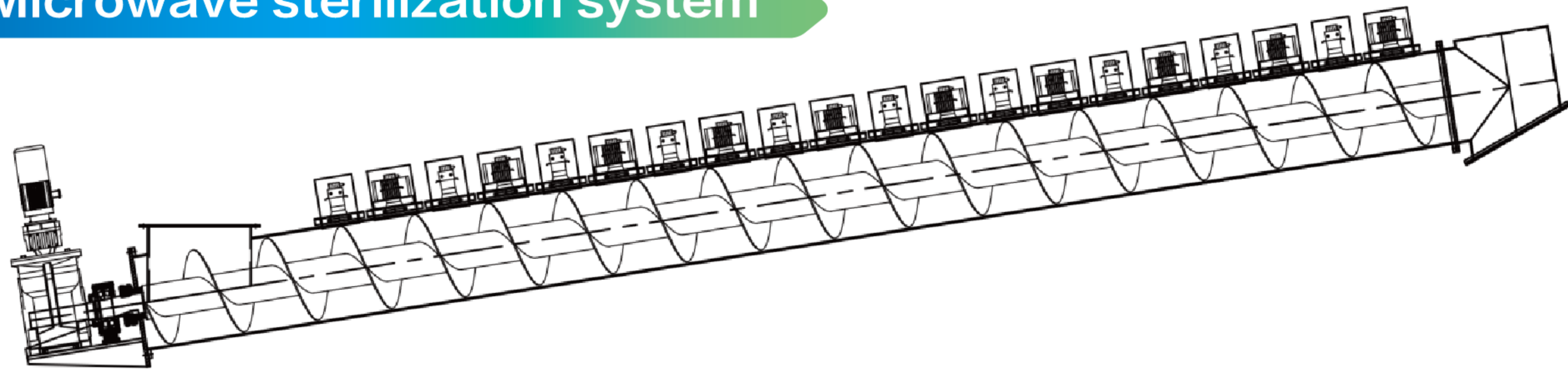

### Composition

Stainless steel cylinder shell, spiral conveying device, motor reducer, temperature keeping device, ventilator, material detecting device, spiral rotating counting device, microwave generator, microwave generator cold water device, temperature sensor, steam generator and its pipeline and steam valve, etc.

### Function

Disinfection of medical waste in continuous operation after crushing and destruction of the waste (heating is carried out by the dual action of steam injection and microwave radiation). Meet the requirements of HJ 229-2021 "Medical Waste Microwave Disinfection Centralized Treatment Engineering Technical Specification".

### Operation

The microwave disinfection unit disinfects the waste in continuous operation. Heating is carried out by the dual action of steam injection and microwave radiation. Steam is injected into the microwave disinfection unit by four steam nozzles at a predetermined distance from the transfer hopper prior to the first microwave unit. Steam is used to maintain the temperature of the scrap and to provide the proper environment for microwave energy to be used for sterilization.

## Product Operation Logic

#### ▶ Discharge system

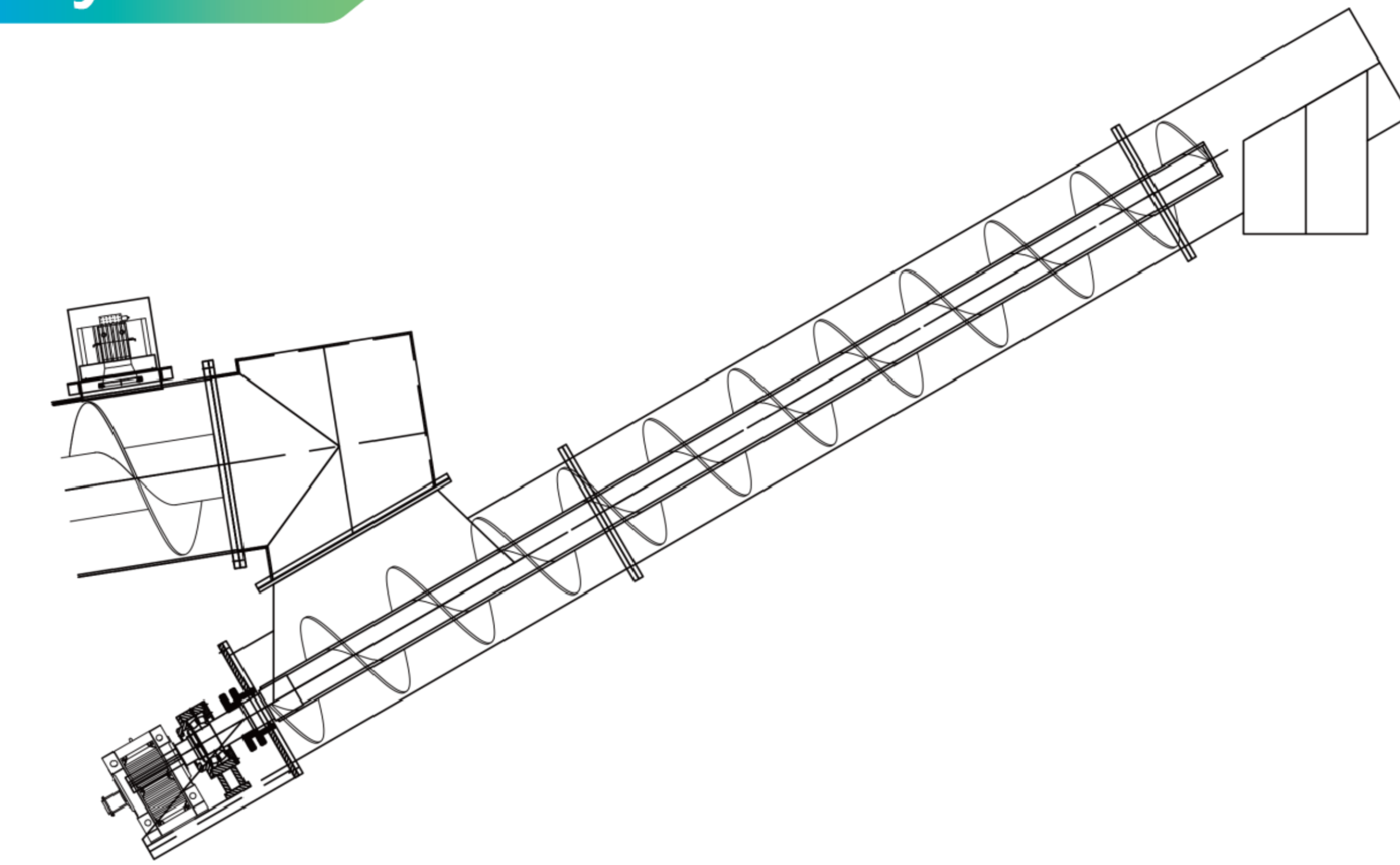

### Product Operation Logic

Stainless steel cylinder shell, spiral conveying device, motor reducer, temperature holding device, material detecting device and temperature sensor.

### Function

The temperature is maintained and the finished sterilized material is transported to the designated residue transporter.

### Operation

The discharge screw conveyor is mounted at the bottom of the temperature holding hopper and is supported by tie rods external to the installation equipment. It is used to transport the decontaminated waste to the waste container below the outlet.

A temperature sensor is mounted at the bottom of the temperature holding hopper to monitor the temperature of the waste in the temperature holding section and will indicate a temperature failure if the temperature falls below 95° C for more than five minutes.

The bottom of the temperature holding section discharge conveyor is insulated to protect the operator from possible burns due to the high temperatures inside. The upper section is not insulated to allow the waste to cool before leaving the conveyor.

#### ▶ Electrical control system

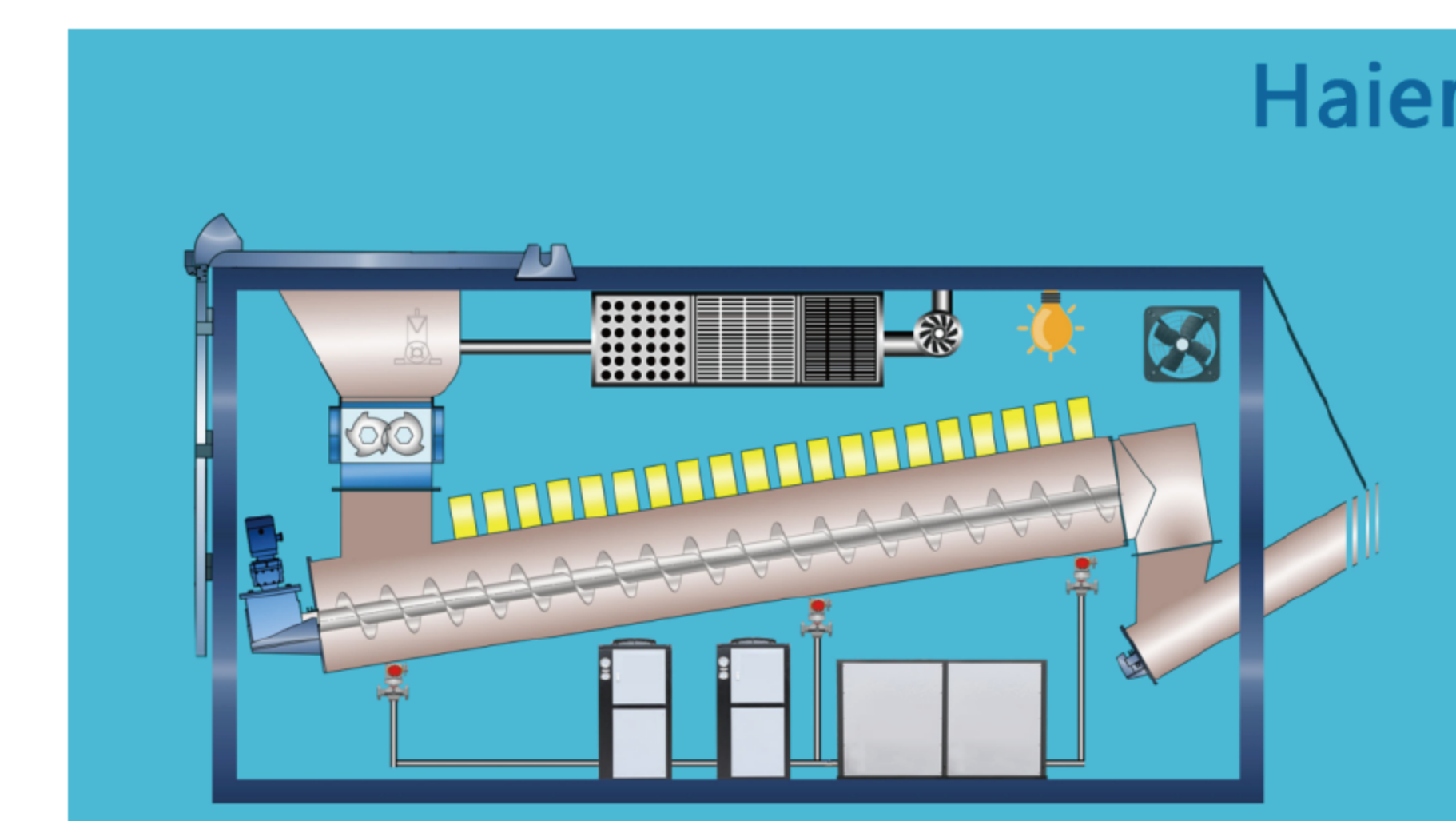

## Product Operation Logic

### Composition

This system adopts PLC as the main control unit, supporting touch industrial control machine and three-color buzzer alarm light. The touch screen sets multiple operation pages to realize data filing, manual operation, status display, fault inquiry, parameter setting and other functions.

### System Control

It is the center of the whole control system, and the running mechanism is controlled directly and indirectly through the electric system; using industrial Ethernet to connect with the industrial control machine for efficient communication, the man-machine control system realizes real-time intuitive manual operation function. Emergency stop, manual \ automatic, start, stop, one key start, one key stop and other control buttons are installed to realize the functions required by the system.

### System Operation

It is the main operation and information display device of the system; touch industrial control machine is installed and connected to the system to realize information display and operation control functions, such as displaying information related to the normal operation of the system and abnormal information, setting the execution program, setting other system parameters, and manually operating and controlling each mechanism in the system; emergency stop control button is installed to realize the functions required by the system.



## Intelligent medical waste disinfection treatment equipment

High Efficiency, Environmental Protection, Energy Saving

## Part of the product specifications and parameters

Model	Material	volume	Crushing system Power	Sterilisation Power	Dimensions (mm)	Ancillary Facilities	Total power
YFXDG100~G500	Stainless steel + alloy steel	100L-500L	5.5kw~11kw	3.3kw~4.5kw	2000*1500*1800-2300*1800*1840	Steam generator, water chiller, water softener, electric control box, tailpipe equipment, etc. (all optional)	14.8kw~21.5kw

Model	Lifting systems Bin	Lifting systems Power source	Lifting systems Material	Silos Volume	Silos Material	Silos Presses	
YFXDG1000~10000	660L	4kwHydraulic systems	Stainless steel	1m³~1.2m³	Stainless steel	YES	
	Crushing systems Blade	Sterilisation bins Power	Sterilisation bins Bin size	Sterilisation bins Microwave generator	Discharge spiral Power	Total power	
	22kw	Φ345*30 D550	2.2~3kw	530-8500	1.1kw*8~1.1kw*20	3kw	97-176kw