

PREMIUM INSIGHTS – GAIN REAL-TIME INSIGHT INTO YOUR PROCESS

Process Insights' products and solutions deliver innovative and differentiated analysis and measurement solutions and technologies that add high value to our customers and protect the environment.

Our commitment is to deliver smart and affordable innovation that optimizes process, improves safety, and transforms our world.

CENTERS OF EXCELLENCE

PROVIDING PROVEN SOLUTIONS FROM A GLOBAL TECHNOLOGY LEADER

COSA Xentaur

4140 World Houston Parkway
Suite 180
Houston, TX 77032
USA
+1 713 947 9591
www.cosaxentaur.com
sales@cosaxentaur.com

Process Insights – The Americas

4140 World Houston Parkway
Suite 180
Houston, TX 77032
USA
+1 713 947 9591
info@process-insights.com

Process Insights – EMEA

ATRICOM
Lyoner Strasse 15
60528 Frankfurt
Germany
+49 69 20436910
info@process-insights.com

Process Insights – APAC

Wujiang Economic and Technology
Development Zone
No. 258 Yi He Road, 215200 Suzhou
Jiangsu Province China
+86 400 086 0106
info@process-insights.com



PRODUCT DATASHEET

COSA 9800™

Zero Hydrocarbon Emissions Calorimeter

Fast and Accurate Measurement of Heating Value, Wobbe Index, and Combustion Air Requirement Index (CARI)



OUR PREMIUM GLOBAL BRANDS



Zero Hydrocarbon Emissions

Accurate Measurements

Low Maintenance

- Flare Stack Control
- Fuel Optimization
- Gas Blending
- Custody Transfer
- Flare Monitoring
- Biogas
- Natural gas
- Refinery gases
- Heating Value: 0-3000 BTU/SCF
- Wobbe Index: 0-2750 BTU/SCF
- CARI Index: 0-20
- Wall mount with optional stand or cart

COSA 9800™ Calorimeter Features

- Zero HC Emissions
- Fast Response Injection Style
- Direct Measurement of Calorific Heating Value
- BTU Measurement Range 0-3000 BTU/scfh
- Handles High Sulfur Concentrations
- H₂ Measurement Option
- Industrial PLC System, Touchscreen HMI
- High Temperature Combustion
- Flameless / No Flameouts
- Built for Indoor, Outdoor, Dirty, and Corrosive Environment
- Precise Measurement of Air Fuel Ratio

Measurement Principle: Residual Oxygen Measurement

The COSA 9800™ Calorimeter uses the measuring principle based on the analysis of the residual oxygen content in fuel or flare gas after combustion of the sample. A small constant volume of sample gas is injected into a continuous flow of combustion air with each measurement cycle, providing a precisely maintained fuel/air ratio profile.

The fuel air mixture is oxidized in the combustion furnace at 1000°C, and the residual oxygen concentration of the combustion sample is measured by a zirconia oxide sensor. The residual oxygen provides an accurate method of measuring Heating Value with optional measurement of Wobbe Index correlated to Specific Gravity of the sample gas. Higher temperature reduces maintenance of the instrument; varying temperature up to 1000°C.

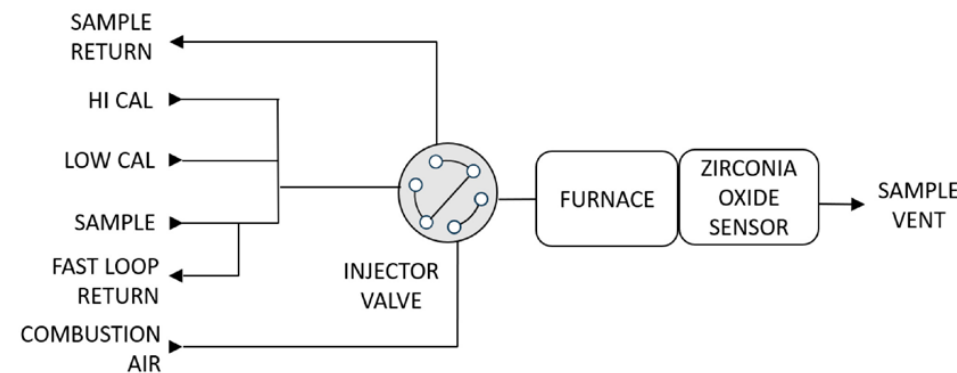

The majority of the sample gas will return to the process gas stream through the fast loop so there is no hazardous hydrocarbon emission. Only the small amount of sample gas and air mixture is completely burned in the combustion process resulting in extremely low, non-hazardous (CO₂) emissions.

Additional Features

- Compact, sturdy O₂ Cell is designed to be cost-effective, and for ease of maintenance and service
- Internal sample system up to 50°C with options to 100°C or 150°C
- Full measurement range 0-3000 BTU/SCFH without the need of a specific gravity meter

Higher Temperatures, Reliability Improvements

The COSA 9800 Calorimeter maintenance requirements are low. It's easy to maintain. The zirconia oxide sensor is mounted in the electronics cabinet for added safety and speedy access.

Higher furnace temperatures provide complete oxidization of any molecular-bound sulfur compounds, virtually eliminating the typical accumulation of uncombusted sulfur products in the furnace vent further reducing instrument maintenance. Combined with use of proper sample conditioning, the COSA 9800 can operate unattended for several months. All compartments are easily accessible through separate doors on the front side of the enclosure.

SPECIFICATIONS Analyzer Performance

Model:	COSA 9800 Calorimeter
Sample Gas:	Natural gas, fuel gas, refinery gases, biogas, flare gas, etc.
Ranges:	Heating Value: 0-3000 BTU/SCF, Wobbe Index: 0-2750 BTU/SCF, CARI Index: 0-20
Accuracy:	± 1% full scale
Repeatability:	±0.5% BTU/SCF
Response Time:	< 30 sec
Ambient Temperature:	Base: 5°C (41°F) to +40°C (104°F), -20°C (-4°F) to +55°C (104°F)
Outputs:	(optional) 4 Analog Outputs, 4 Digital Outputs, 2 (optional)
Communication:	Modbus over TCP/IP
Specific Gravity (optional):	Range: 0.2-2.2 RD
Enclosure:	IP65 NEMA 4X
Furnace Temperature:	Up to 1000°C

Utilities

Power Supply: Power	110/220 V AC, 50/60
Consumption: Air	HZ 2000 V A Base
Consumption:	180 SCFH (Analyzer), 296 SCFH (with Purge) @ 80 psig
Sample:	Sample usage 100cc/min
Sample Pressure:	5-100 psig
Mounting	Wall mount with optional stand or cart available 200 lbs. (91k kg) 30" H x
Weight:	40" W x 14" D (762 mm x 1016 mm x 356
Dimensions:	

All features, functionality and other product specifications are subject to change without notice or obligation.

Analyzer Construction

The COSA 9800 Calorimeter is housed in a powder coated NEMA4x (IP65) cabinet suitable for outdoor installations without additional temperature controlled shelter. For extreme climate conditions, the standard operating temperature range of the COSA 9800 Calorimeter can be extended with the addition of a cabinet heater and/or vortex cooler. Enclosure is wall mounted with optional stand. The analyzer cabinet has three compartments: the gas mixing compartment, the combustion furnace compartment, and the electronics compartment.



The Sample Conditioning Enclosure contains sample conditioning and the gas mixing system. Components in this compartment are intrinsically safe. The gas mixing compartment is heated to avoid condensation of heavier gas constituents.

The Combustion Furnace Enclosure contains the combustion furnace and the zirconia oxide sensor is located separately in electronics cabinet. Both electronics compartment and combustion furnace compartment can optionally be purged for Class 1 Div 2 applications.

The Electronics Enclosure contains the industrial PLC system and touchscreen HMI, which performs all instrument control functions and calculations. Results are available through digital and analog outputs and a touchscreen HMI, which displays Heating Values and Wobbe Index in BTU/SCF or MJ/Nm³, residual O₂ in %, Cell voltage in mV, relative density (optional), and CARI (Combustion Air Requirement Index).