

WBGT SD Card Datalogger

800037

Instruction Manual

SPER
SCIENTIFIC

Environmental Measurement Instruments

WBGT SD Card Datalogger 800037

Copyright ©2010 by Sper Scientific

ALL RIGHTS RESERVED

Printed in the USA

The contents of this manual may not be reproduced or transmitted in any form or by any means electronic, mechanical, or other means that do not yet exist or may be developed, including photocopying, recording, or any information storage and retrieval system without the express permission from Sper Scientific.

8281 E. Evans Rd. Suite #103,
Scottsdale, AZ 85260

Tel: (480) 948-4448 | Fax: (480) 967-8736

Web: www.sperscientific.com

TABLE OF CONTENTS

INTRODUCTION	4
FEATURES.....	5
MATERIALS SUPPLIED.....	6
POWER SUPPLY	7
METER COMPONENTS	8
KEYPAD	10
SETUP.....	11
MEASUREMENT PROCEDURES	15
DATALOGGER	20
BATTERY REPLACEMENT	21
TROUBLESHOOTING	21
APPENDICES	22
OPTIONAL ACCESSORIES.....	24
SPECIFICATIONS	25
WARRANTY	28

INTRODUCTION

The Sper Scientific WBGT SD Card Datalogger (Model 800037) is an intelligent meter that reads wet bulb globe temperature, wet bulb temperature, dew point temperature, humidity and air temperature, and black globe temperature.

You can use the meter almost anywhere to determine appropriate exposure levels and meet OSHA or other safety standards for high temperatures to avoid heat exhaustion and heat-related injuries during athletic events, military exercises, and industrial activities.

This meter features a real time SD memory card datalogger. Standard, portable SD memory cards provide unlimited data storage and upload pre-formatted data directly to Excel, eliminating the need for cables or software. Each data set includes the temperature measurement (wet bulb globe temperature, wet bulb temperature, dew point temperature, humidity and air temperature or black globe temperature) and the time and date.

FEATURES

- Reads indoor/outdoor wet bulb globe temperature, wet bulb temperature, dew point temperature, humidity and air temperature, and black globe temperature
- SD memory card datalogger
- Manual datalogger option
- Highly accurate microcomputer circuit
- Highly accurate Pt sensor for globe temperature measurement
- Fast response time for humidity measurement
- Direct measurement of the radiation effect with a 75 mm brass black ball
- Sensor protecting mechanism
- Direct upload of data to Excel
- Internal clock and calendar
- WBGT alarm
- Touch-tone
- Tripod mounting screw
- Built-in tabletop stand
- Maximum and minimum
- Hold function
- Auto-power-off
- Low battery indicator
- Backlight

MATERIALS SUPPLIED

- Meter
- SD Card
- Brass Black Ball with Sensor
- 6 AA Batteries
- Instruction Manual
- Soft Carrying Case

POWER SUPPLY

This meter can be powered by six AA (1.5 V, UM3) batteries or an optional 9 Volt DC adapter. See page 21 for battery replacement instructions.

Plug the adaptor into the power port labeled “DC 9V,” located on the side of the meter (under the protective black cover).

Note...

When using the adapter, the meter will remain permanently on and the **POWER** button will be disabled.

METER COMPONENTS

Bottom of Meter

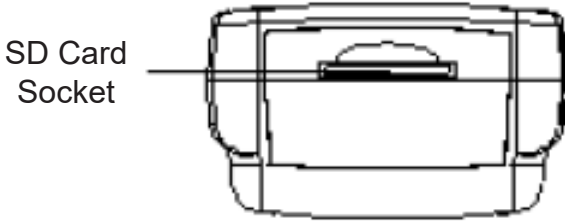

Side of Meter

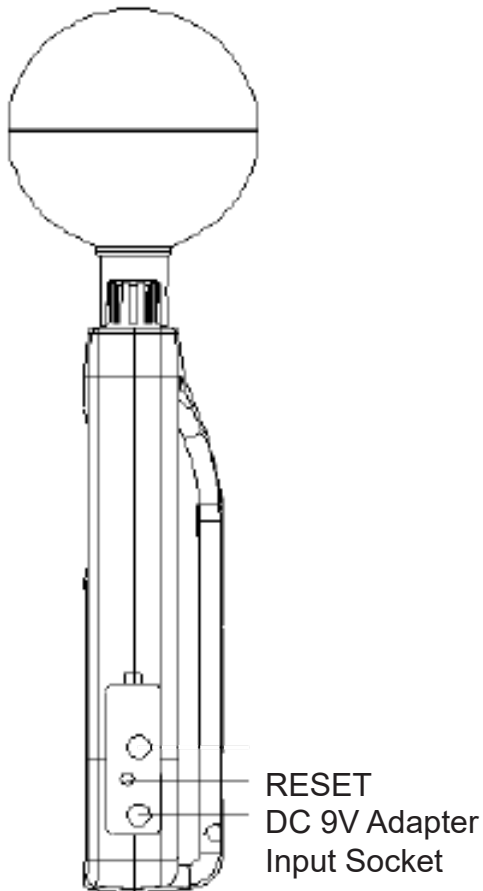

METER COMPONENTS

Back of Meter

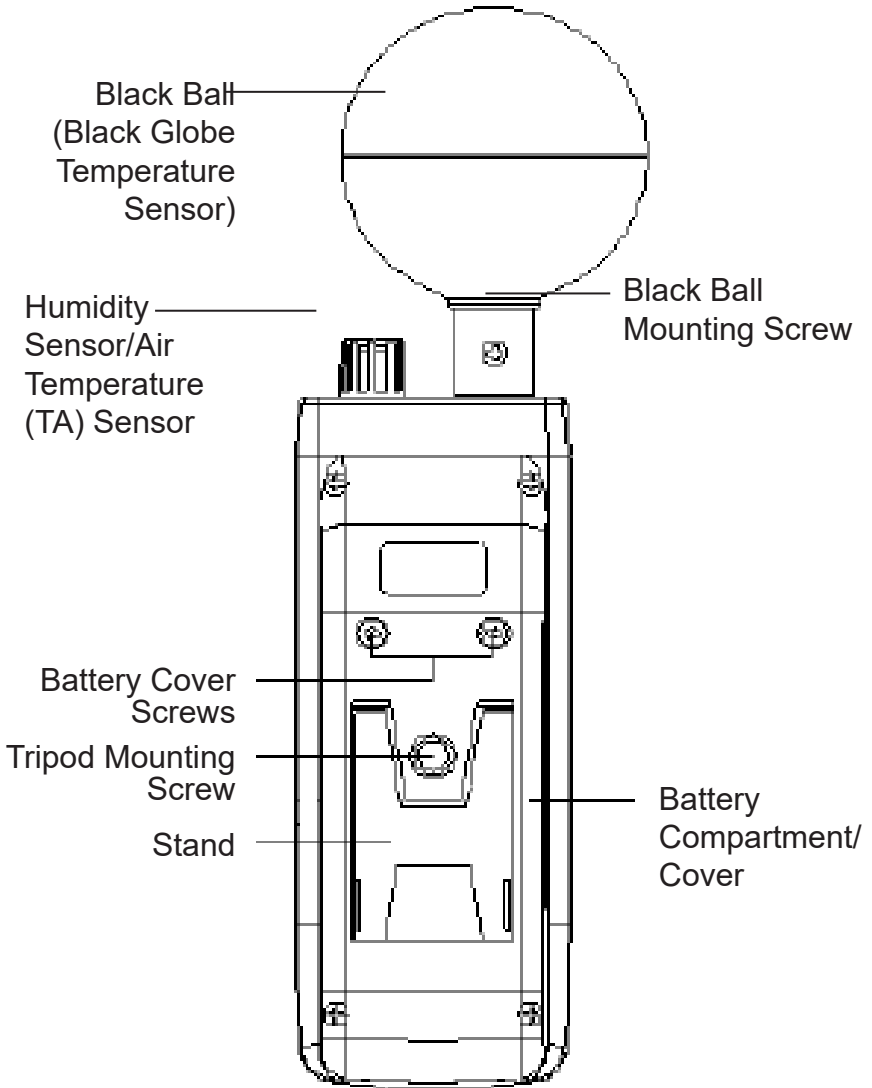

KEYPAD

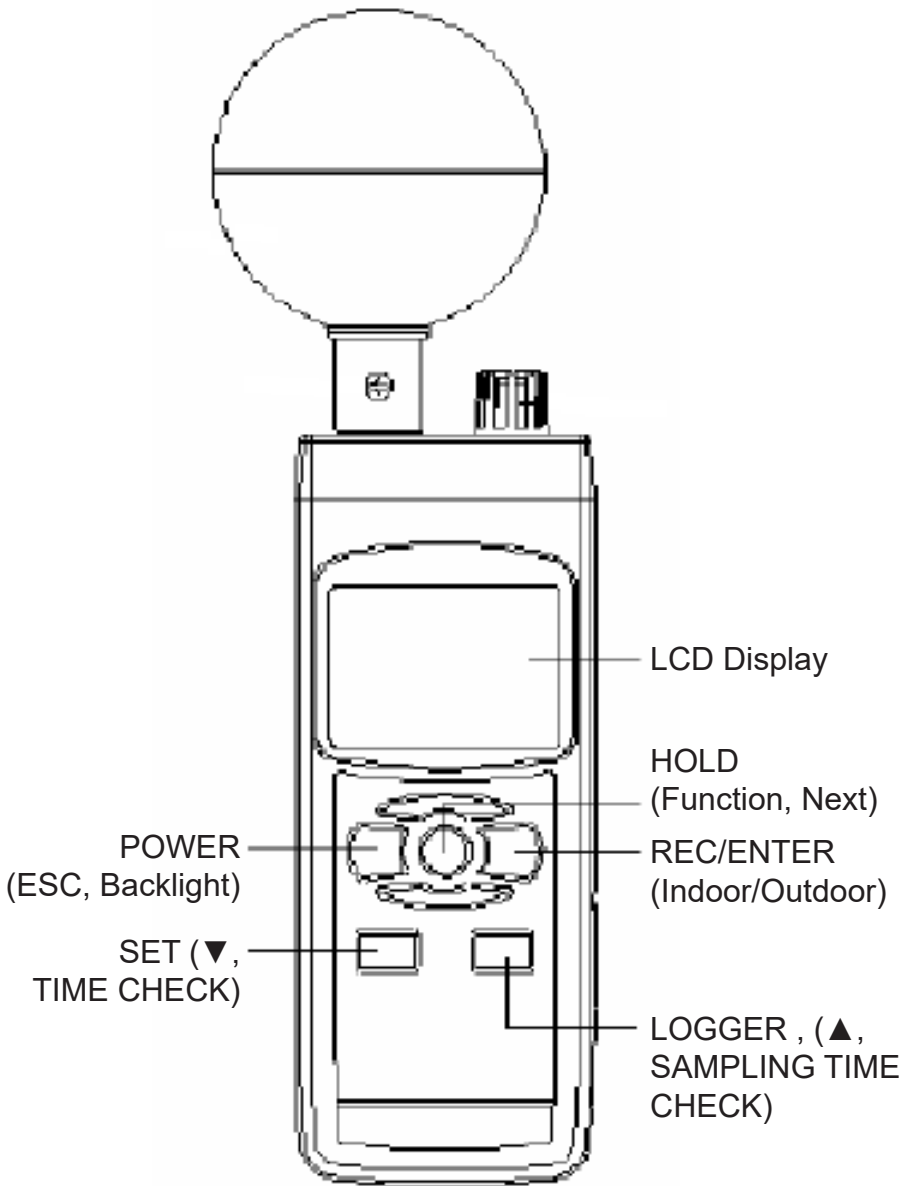

SETUP MODE

The advanced Setup Mode allows you to customize the following meter preferences and defaults:

- Real Time Clock
- WBGT Alarm
- Decimal Type
- Auto Power Off
- Touch-Tone
- Temperature Units
- Sampling Time
- SD Memory Card Format

Note...

The setup functions can be performed under any parameter but not while utilizing the datalogger function. Once selections are saved, the meter will default to the selected preferences.

1. Press **POWER** to turn the meter **on**.
2. Press **SET** for 2 seconds or longer to enter Setup Mode.
3. Press **NEXT** to cycle through the setup functions.

Note...

Press **ESC** to exit Setup Mode. The meter will return to Normal Mode.

Real Time Clock

1. Enter the clock function from Setup Mode (see page 11). “dAtE” appears on the LCD.
2. Press **ENTER**. The year will flash on the LCD.
3. Press **▲** or **▼** to adjust the value. Press **ENTER** to save the value.
4. Repeat Step 3 to adjust the month, date, hour, minute and second.

Note...

This procedure adjusts the meter’s internal clock. The internal clock will function when the meter is turned **off** but only when the batteries have adequate power (not with low battery power.)

WBGT Alarm

1. Enter the WBGT alarm function from Setup Mode (see page 11). “AL” appears on the LCD.
2. Press **▲** or **▼** to adjust the WBGT alarm value. Press **ENTER** to save the value.

Note...

The alarm will sound when the WBGT measurement exceeds the set WBGT alarm value.

Decimal Type

Although the decimal is commonly expressed as the “.” symbol (i.e., 20.6 or 1000.53), some (European) countries use a “,” symbol to represent the decimal (i.e., 20,6 or 1000,53). The meter defaults to the period symbol.

To adjust:

1. Enter the decimal type function from Setup Mode (see page 11). “dEC” appears on the LCD.
2. Press ▲ or ▼ to select Basic (.) or Euro (,). Press **ENTER** to save the selection.

Auto Power Off

The meter automatically turns **off** after 10 minutes of inactivity, however this function can be disabled.

1. Enter the auto power off function from Setup Mode (see page 11). “PoFF” appears on the LCD.
2. Press ▲ or ▼ to select yes (auto power off enabled) or no (auto power off disabled). Press **ENTER** to save the selection.

Touch-Tone

1. Enter the touch-tone function from Setup Mode (see page 11). “bEEP” appears on the LCD.
2. Press ▲ or ▼ to select yes (touch-tone enabled) or no (touch-tone disabled). Press **ENTER** to save the selection.

Temperature Units

1. Enter the temperature units function from Setup Mode (see page 11). “t-CF” appears on the LCD.
2. Press ▲ or ▼ to select C (degrees Celcius) or F (degrees Farhenheit). Press **ENTER** to save the selection.

Sampling Time

The sampling time (seconds) is the time allotted between successive measurements. To adjust the sampling time:

1. Enter the sampling time function from Setup Mode (see page 11). “SP-t” appears on the LCD.
2. Press ▲ or ▼ to adjust the value (0, 1, 2, 5, 10, 30, 60, 120, 300, 600, 1800, 3600). Press **ENTER** to save the value.

SD Memory Card Format

Enabling this function will format the SD memory card to work specifically with your meter. Formatting the SD card will erase any previous memory on the card. New SD cards should be formatted to work with your meter.

1. Enter the SD memory card format function from Setup Mode (see page 11). “Sd F” appears on the LCD.
2. Press ▲ or ▼ to select yes (format the SD memory card) or no (do not format the SD memory card). Press **ENTER** to confirm your selection. If selecting yes, “yES Enter” will appear on the LCD, press **ENTER** again and the meter will format the SD card.

MEASUREMENT PROCEDURES

Turning the Unit On/Off

1. Press **POWER** to turn the meter on.
2. Press and hold **POWER** for 2 seconds to turn the meter **off**.

Selecting the Function

1. Press and hold **FUNC** to cycle through the options listed below. Release **FUNC** when you reach the desired function.
 - Wet bulb globe temperature “_bgt” appears on the LCD.
 - Wet bulb temperature “_b” appears on the LCD.
 - Dew point temperature “dP” appears on the LCD.
 - Humidity and air temperature “tA” appear on the LCD.
 - Black globe temperature “tg” appears on the LCD.

Note...

The meter defaults to °C. To change the temperature unit, see page 14.

Wet Bulb Globe Temperature

1. Press **POWER** to turn the meter on.
2. Press and hold **FUNC** to cycle through the options until “_bgt” appears on the LCD. Release the **FUNC** button. The WBGT value appears on the upper display and “_bgt in” or “_bgt out” appears on the lower display to indicate the setting for indoor or outdoor use.

Note...

Use the “in” setting for indoor use or outdoor with no sun.

Use the “out” setting for outdoor use with full sun. To change the setting, press and hold **In/Outdoor** and release when the desired selection appears on the LCD.

3. To enable/disable the WBGT audible alarm, see page 12.

Wet Bulb Temperature

1. Press **POWER** to turn the meter **on**.
2. Press and hold **FUNC** to cycle through the options until “_b” appears on the LCD. Release the **FUNC** button. The wet bulb temperature value appears on the upper display.

Dew Point Temperature

1. Press **POWER** to turn the meter **on**.
2. Press and hold **FUNC** to cycle through the options until “dP” appears on the LCD. Release the **FUNC** button. The dew point temperature value appears on the upper display.

Humidity and Air Temperature

1. Press **POWER** to turn the meter **on**.
2. Press and hold **FUNC** to cycle through the options until “tA” appears on the LCD. Release the **FUNC** button. The humidity value appears on the upper display and the air temperature value appears on the lower display.

Black Globe Temperature

1. Press **POWER** to turn the meter on.
2. Press and hold **FUNC** to cycle through the options until “tg” appears on the LCD. Release the **FUNC** button. The black globe temperature value appears on the upper display.

Hold Function

1. When measuring any parameter, press **HOLD** to freeze the reading on the display. “HOLD” will appear on the LCD. Press **HOLD** again to release the hold function.

Maximum and Minimum

To record maximum and minimum readings:

1. When measuring any parameter, press **REC** to begin recording the maximum and minimum values. “REC” appears on the LCD.
2. Press **REC**. The maximum value and “REC MAX” will appear on the LCD.
3. Press **REC**. The minimum value and “REC MIN” will appear on the LCD.
4. To delete the maximum or minimum value, press **HOLD**. “REC” appears on the LCD and the meter will begin recording the maximum and minimum values again.
5. To exit the min/max function, press and hold **REC** for 2 seconds or longer. The meter will return to Normal Mode.

Backlight

1. The backlight turns on automatically when the meter is turned on.
2. Press to turn the backlight off or on.

View Real Time Clock

1. Press **TIME CHECK**. The time information (Year, Month/Date, Hour/Minute) will appear on the lower display.

View Sampling Time

1. Press **SAMPLING CHECK**. The sampling time (in seconds) will appear on the lower display.

Note...

The time information and sampling time can be viewed in Normal Mode.

Preparing the Datalogger

1. Insert the SD card into the SD card socket on the bottom of the meter, ensuring that the front of the SD card faces the back of the meter.
2. Format the SD card as needed (see page 14).
3. Set the real time clock if using the meter for the first time (see page 12).
4. Set the decimal type if using the meter for the first time (see page 13).

Auto Datalogging

1. Set the sampling time to ≥ 1 second. Refer to page 14.
2. Press **REC**. "REC will appear on the LCD.

3. Press **LOGGER**. “REC” will flash on the LCD and the alarm will sound while the measurement data and time information are saved to memory.
4. To pause datalogging, press **LOGGER**. The meter will temporarily stop recording and “REC” will stop flashing on the LCD. Press **LOGGER** again to resume datalogging. “REC” will flash on the LCD.
5. To finish datalogging, while the datalogger is paused, press **REC** for 2 seconds or longer. “REC” will disappear from the LCD to indicate that datalogging has ended.

Note...

To enable/disable the touch-tone feature, see page 13.

Manual Datalogging

1. Set the sampling time to 0 seconds. Refer to page 14.
2. Press **REC**. “REC” will appear on the LCD.
3. Press **LOGGER**. “REC” will flash on the LCD and the alarm will sound once while the measurement data and time information are saved to memory. The position (location) number will appear on the bottom of the LCD and will also be recorded on the SD card.

Note...

To enable/disable the touch-tone feature, see page 13. To change the position number, press ▼. The position number will flash on the LCD. Press ▲ or ▼ to set the position number (from 1 to 99). To indicate the position location, P x (x = 1 to 99) will appear on the lower display. After selecting the position number, press **ENTER** to confirm.

4. To finish datalogging, press **REC** for longer than 2 seconds. “REC” will disappear from the LCD to indicate that datalogging has ended.

DATALOGGER

SD Card Data Structure

1. The first time a SD card is used in this meter, a folder WBA01 will be generated.
2. If the datalogger is being used for the first time, a new file WBA01001.XLS will be generated under the route WBA01\. After exiting the datalogger and executing the function again, the data is saved to the WBA01001.XLS file until the data reach 30,000 data columns. A new file will then be generated (i.e., WBA01002.XLS).
3. The folder WBA01\ will hold 99 files. A new route (i.e., WBA02\) will be generated when exceeding 99 files.
4. The file's route structure:

```
WBA01\  
    WBA01001.XLS  
    WBA01002.XLS  
    .....  
    WBA01099.XLS  
WBA02\  
    WBA02001.XLS  
    WBA02002.XLS  
    .....  
    WBA02099.XLS  
WBAXX\  
    .....  
    .....
```

Note...

XX: Maximum value is 10.

BATTERY REPLACEMENT

This meter uses six AA (1.5 V, UM3) batteries. When the low battery indicator  appears on the LCD, battery replacement is needed. After the icon appears on the LCD, in-spec measurement can still be made for several hours before becoming inaccurate.

1. Press **POWER** to turn the meter **off**.
2. Unscrew the battery cover and remove from the meter.
3. Remove the old batteries and replace with six new AA batteries, ensuring correct polarity.
4. Replace the battery cover. Tighten the screws on the battery cover to secure to the meter.

TROUBLESHOOTING

System Reset

If the meter is not functioning properly (i.e., the system is frozen and the keypad is non-operational), reset the meter:

1. Press **POWER** to turn the meter **on**.
2. Use a small tool (such as a disassembled paperclip or a pin) to press the **RESET** button (located on the right side of the meter under the protective black cover). Wait a few seconds for the meter to restart.

APPENDICES

Recommended heat exposure levels for working and physical activity (permissible heat exposure threshold):

Work/rest regimen	Light	Moderate	Heavy
Continuous work	30°C (86°F)	26.7°C (80°F)	25°C (77°F)
75% work, 25% rest	30.6°C (87°F)	28°C (82°F)	25.9°C (78°F)
50% work, 50% rest	31.4°C (89°F)	29.4°C (85°F)	27.9°C (82°F)
25% work, 75% rest	32.2°C (90°F)	31.1°C (88°F)	30°C (86°F)

Source: AAGIH 1992 (The American Conference of Governmental Industrial Hygienists)

Wet Bulb Globe Temperature Formula

Indoor/outdoor with no sun:

$$\text{WBGT} = (0.7 \times \text{WB}) + (0.3 \times \text{TG})$$

Outdoor with full sun:

$$\begin{aligned} \text{WBGT} &= (0.7 \times \text{WB}) \\ &+ (0.2 \times \text{TG}) \\ &+ (0.1 \times \text{TA}) \end{aligned}$$

WBGT Index and Physical Exercise

WBGT	Flag	Activity Intensity
< 26.7°C (< 80°F)	White	Normal activity. Take caution.
26.7 to 29.4°C (80 to 84.9°F)	Green	Discretion is required in planning intense physical activity.
29.5 to 31°C (85 to 87.9°F)	Yellow	Intense activity for new and non-acclimated persons should be curtailed.
31.1 to 32.2°C (88 to 89.9°F)	Red	Intense exercise must be curtailed for those with less than 12 weeks training in hot weather. Be on high alert.
≥ 32.2°C (≥ 90°F)	Black	Cancel all outdoor exercise.

OPTIONAL ACCESSORIES

- 840059 2GB SD Card
- 840090 Water Resistant Instrument Pouch
- 840093 Field Tripod
- 840097 AC Adaptor

SPECIFICATIONS

Circuit	Custom one-chip of microprocessor LSI circuit
Display	LCD size: 52 mm x 38 mm Backlight function
Measurement Unit	Wet bulb globe temperature Black globe temperature Air temperature Wet bulb temperature Humidity Dew point temperature
Sampling Time of Display	Approximately 1 second
Memory Card	SD card 1 GB to 16 GB
Operating Temperature	0 to 50°C
Operating Humidity	< 85% RH
Power Supply	Alkaline or heavy duty DC 1.5 V battery (UM3, AA) x 6 pieces
	DC 9V adapter input (AC/DC power adapter is optional)
Power Current	Normal Operation (without use of the datalogger or backlight): Approximately DC 5 mA
	Datalogger Operation (backlight is off): Approximately DC 25 mA
	If the backlight is on, the power consumption will increase by approximately 11 mA.
Dimensions	Meter: 177 x 68 x 45 mm 7 x 2 ¾ x 2" Brass Black Ball: Round, 75 mm diameter
Weight	1 lb. (0.45 kg)

SPECIFICATIONS

Wet Bulb Globe Temperature

Range	°C	Indoor	@95% RH -10°C to 52°C
		Outdoor	(@0% RH -10°C to 34°C)
	°F	Indoor	@95% RH 14°F to 126°F
		Outdoor	(@0% RH 14°F to 93°F)
Accuracy (Indoor)	°C	± 1°C (15 to 59°C) ± 1.5°C (Others)	
	°F	± 1.8°F (59 to 138°F) ± 2.7°F (Others)	
Accuracy (Outdoor)	°C	± 1.5°C (15 to 56°C) ± 2°C (Others)	
	°F	± 2.7°F (59 to 132°F) ± 3.6°F (Others)	

Air Temperature

Range	°C	0 to 50°C
	°F	32 to 122°F
Resolution	°C	0.1°C
	°F	0.1°F
Accuracy (@15 to 40°C)	°C	± 0.8°C
	°F	± 1.5°F

Black Globe Temperature

Range	°C	-10 to 65°C
	°F	14 to 149°F
Resolution	°C	0.1°C
	°F	0.1°F
Accuracy (@15 to 40°C)	°C	± 0.6°C
	°F	± 1.1°F

SPECIFICATIONS

Humidity

Range	5 to 95% RH
Resolution	0.1% RH
Accuracy	≥ 70% RH: ± (3% reading + 1% RH) < 70% RH: ± 3% RH

Dew Point Temperature

°C	Range	-25.3 to 48.9°C
	Resolution	0.1°C
°F	Range	-13.5 to 120.1°F
	Resolution	0.1°F

Wet Bulb Temperature

°C	Range	@95% RH -10°C to 58°C (@0% RH -10°C to 25°C)
	Resolution	0.1°C
°F	Range	@95% RH 14°F to 136°F (@0% RH 14°F to 77°F)
	Resolution	0.1°F

Note...

The dew point and wet bulb temperature values are calculated automatically using the humidity/air temperature measurement.

WARRANTY

Sper Scientific warrants this product against defects in materials and workmanship for a period of **five (5) years** from the date of purchase, and agrees to repair or replace any defective unit without charge. If your model has since been discontinued, an equivalent Sper Scientific product will be substituted if available. This warranty does not cover probes, batteries, battery leakage, or damage resulting from accident, tampering, misuse, or abuse of the product. Opening the meter to expose its electronics will void the warranty.

To obtain warranty service, ship the unit postage prepaid to:

SPER SCIENTIFIC LTD.
8281 E. Evans Rd., Suite 103
Scottsdale, AZ 85260

The defective unit must be accompanied by a description of the problem and your return address. Register your product online at www.sperwarranty.com within 10 days of purchase.

Please note: The most current version of the manual can always be found at www.sperdirect.com