

UVA/B Light Meter

850009

Instruction Manual

SPER
SCIENTIFIC

Environmental Measurement Instruments

UVA/B Light Meter - 850009

Copyright ©2014 by Sper Scientific

ALL RIGHTS RESERVED

The contents of this manual may not be reproduced or transmitted in any form or by any means electronic, mechanical, or other means that do not yet exist or may be developed, including photocopying, recording, or any information storage and retrieval system without the express permission from Sper Scientific.

CONTENTS

INTRODUCTION	3
FEATURES	4
MATERIALS SUPPLIED	4
LCD DISPLAY	5
BASIC FUNCTIONS	6
MODE AND UNIT SELECTION	7
MEMORY	10
UVA/B SENSOR	12
BATTERY REPLACEMENT	14
MAINTENANCE	14
SPECIFICATIONS	15
WARRANTY	16

INTRODUCTION

The Sper Scientific UVA/B Light Meter (Model 850009) is a light-weight, portable instrument that measures damaging UV (ultraviolet) light in both natural and manmade environments.

The UV Light Meter measures long and medium wave UV-A/B light for applications such as forensics, chromatography, electrophoresis and dermatology.

You can use the meter almost anywhere to determine UV light intensity and avoid the harmful effects of overexposure.

FEATURES

- Tripod Mounting Socket
- High and low measurement range in milliwatts per square centimeter (mW/cm^2) or microwatts per square centimeter ($\mu\text{W}/\text{cm}^2$)
- Backlit LCD
- Magnetic Mount
- Simultaneous Display of Minimum, Maximum, Average and Recorded Data
- Zero Point Reset
- Hold Function
- 4 Digit Dual Display
- 20 Points Memory
- Automatic Measuring
- Low Battery Indicator

MATERIAL SUPPLIED

- Meter
- UV Probe
- Magnetic Mount
- 9 Volt Battery
- Instruction Manual
- Hard Carrying Case

LCD DISPLAY

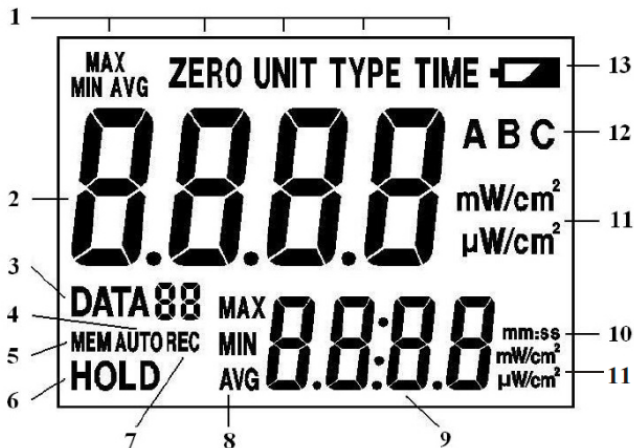

1. Mode
2. Primary Reading
3. Data Log
4. Auto Mode
5. Memory Review
6. Data Hold
7. Record
8. MAX/MIN/AVG
9. Secondary Reading
10. Time Unit
11. Unit of Measure
12. UV Type
13. Low Battery

BASIC FUNCTIONS

Power On/Off

1. Press and hold the **HOLD** button for 2 seconds to turn the meter on. All symbols on the LCD will appear for 1 second.
2. Press and hold the **HOLD** button for 2 seconds to turn the meter off. All symbols on the LCD will appear for 1 second. Release **HOLD** button.

Reading the LCD Display

1. The primary display indicates measurement value (also referred to as the “average” value).
2. The secondary display indicates the advanced functions or data recording (minimum or maximum reading of the current data set) or your one of your 20 recorded data points.

Meter Function Flow Chart

1. Press **MODE** to choose the main function (MAX/MIN/AVG, Zero, Unit, Type or Time). MAX/MIN/AVG Mode is Normal Mode for this meter and has several sub-functions as indicated in the diagram on the next page.

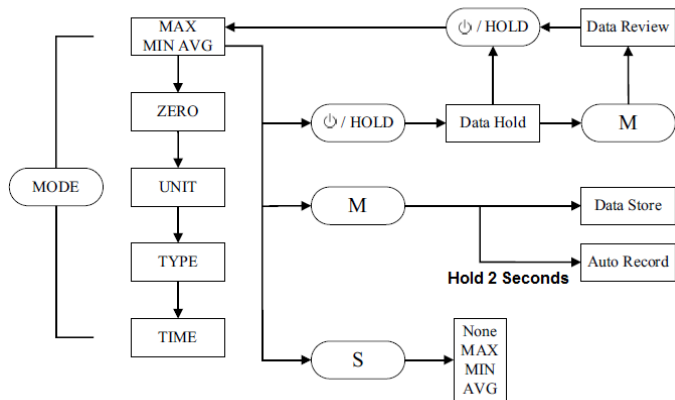

MODE AND UNIT SELECTION

Mode Selection

1. Press **MODE** continuously to cycle through MAX/MIN/AVG, Zero, Unit, Type, and Time Modes, respectively.

Maximum, Minimum and Average/Normal/Current Mode

1. Press **MODE** continuously to cycle through modes until you reach MAX/MIN/AVG.
2. The current measured value appears on the primary display.

3. The primary reading always displays value of measuring. The secondary reading displays the outcomes of the advanced functions or data recording. There are four modes of measuring functions. Press **S** button to change the mode of measuring: None - Max - Min - Avg.
4. Maximum, minimum and average values will appear and freeze on the secondary display and will update only when a new maximum, minimum, or average value is reached on the primary display. Then the secondary display updates automatically. The average value on the secondary display updates according to the detected maximum and minimum values of the current reading.
5. The Max-Min-Avg values can only be recalled if you saved each point to the memory. Press **M** to save the current, max, min, or avg value for each data point and the meter will move to the next data point. The stored data can hold either one current, max, min, or avg value for each data point.
6. Press **S** to reset.

Data Hold

1. While in Normal Mode, press **HOLD** to freeze the secondary display value. "HOLD" will appear on the bottom left corner of the LCD.
2. Press **HOLD** to cancel Hold Mode.

Zero Adjustment

1. Press **MODE** continuously to cycle through modes until you reach Zero Mode.
2. Cover the sensor. If the main display has a reading other than zero, perform the zero adjustment.
3. Cover the sensor and press **S** to zero adjust. The secondary display indicates the adjustment value for your reference.
4. Press and hold **S** for 1 second to clear the adjustment value.

Note...

When the adjustment value is over 10 μW , the measurement value cannot be offset. The main display will show the above range reading, and the secondary display will show “-Err.” Repeat the zero adjustment procedure or contact Sper Scientific.

5. In Zero Mode, press **M** to clear data points 0 to 20.

Unit Selection

1. Press **MODE** continuously to cycle through modes until you reach Unit Mode.
2. Press **S** to choose the unit of measure: $\mu\text{W}/\text{cm}^2$ or mW/cm^2 .

Type Selection

This function is reserved for use in future models.

MEMORY

Manual Recording

In Normal Mode, press **M** to store the current value that appears on the primary display. The flashing DATA (01 to 20) icon stops flashing for 2 seconds and moves to the next storage location. (Refer to Maximum, Minimum and Average/Normal Mode on pages 10-11 for instructions on saving max, min, and avg values.)

Auto Recording

To utilize auto recording, you must first set an interval time for recording measurement values.

Interval Time Setting

1. Press **MODE** continuously to cycle through modes until you reach Time Mode.
2. Continuously press **S** to select an interval time for auto recording of 1, 2, 5, 10, 30 seconds or 1, 3, 5, 10 minutes.

To Auto Record:

1. In Normal Mode, press and hold **M** for 2 seconds. "AUTO" appears next to "REC" on the LCD. As soon as the meter reaches 20 data points, the unit will turn **off**.

Recorded data includes: Irradiation intensity, Max/Min/Avg and unit of measure

2. Press **M** to cancel Auto-Record Mode.

Memory Recall

1. In Normal Mode, press **HOLD**.
2. Press **M** to enter Memory Mode. “MEM” will appear above “HOLD” on the LCD.
3. Press **S** to review data points 0 to 20 on the secondary display. Data point 0 indicates the set time interval between readings when in Auto-Record Mode. (Refer to “Interval Time Setting” section for instructions.) If the data were automatically recorded, “AUTO” appears next to “MEM” during the recall.
4. As you scroll through data points 0 to 20, the saved minimum, maximum, or average value appears on the secondary display.
5. The “MAX”, “MIN” or “AVG” icon will appear on the bottom of the LCD next to the data point number to indicate whether the secondary display represents a maximum, minimum, or average value for that data point. If none of these icons appear, the value represents a stored value at that data point that is not a minimum, maximum or average value.

Clear Data

1. Press **MODE** to select Zero Mode.
2. Press **M** to clear all 20 stored data points.

UVA/B SENSOR

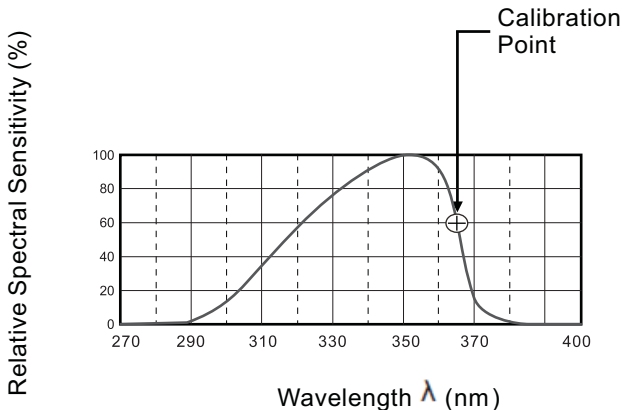

CAUTION:
THE UV SENSOR IS A SENSITIVE INSTRUMENT. TO PREVENT PREMATURE AGING AND THERMAL DESTRUCTION OF THE SENSOR, USE THE SENSOR FOR SHORT-TERM MEASUREMENT IN A SPLASH-PROOF ENVIRONMENT ONLY. THE HOUSING TEMPERATURE MUST NOT EXCEED 50°C. STORE IN A DRY ENVIRONMENT.

UVA/B SENSOR

Portable Handheld Use

(A)

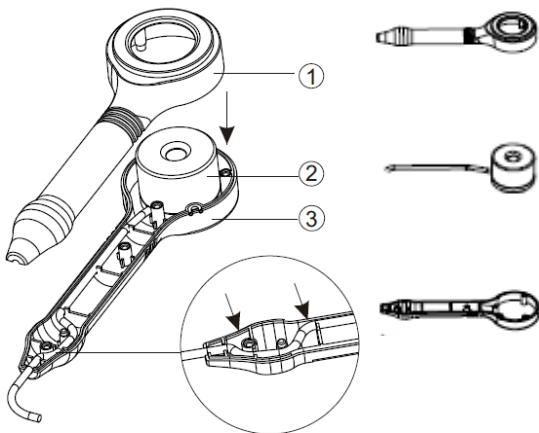

(B)

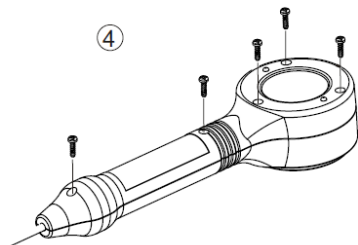

BATTERY REPLACEMENT

This unit requires one 9 Volt battery. The  icon indicates a low battery. To replace:

1. Slide off battery cover from the back of the unit.
2. Insert a 9V battery ensuring correct polarity.
3. Replace battery cover.

MAINTENANCE

1. Dampen a sponge or soft cloth with soap and water to clean the housing.
2. Take care to prevent any liquids or moisture from getting inside the unit during cleaning.

SPECIFICATIONS

Range	1 $\mu\text{W}/\text{cm}^2$ to 40.00 mW/cm^2
Resolution	1 μW and 0.01 mW/cm^2
Accuracy	$\pm 4\% \pm 1$ digit (@23 $\pm 5^\circ\text{C}$)
Wavelength	290 to 370 nm
Calibration Point	365 nm
Temp. Range	0 to 50 $^\circ\text{C}$
Sensor Diameter	35 mm
Meter Dimensions	5 $\frac{1}{2}$ " \times 1 $\frac{7}{8}$ " \times 1 $\frac{1}{8}$ " (140 \times 49 \times 30 mm)
Weight (with battery, sensor and wand)	8.6 oz (246 g)

WARRANTY

Sper Scientific warrants this product against defects in materials and workmanship for a period of **five (5) years** from the date of purchase, and agrees to repair or replace any defective unit without charge. If your model has since been discontinued, an equivalent Sper Scientific product will be substituted if available. This warranty does not cover probes, batteries, battery leakage, or damage resulting from accident, tampering, misuse, or abuse of the product. Opening the meter to expose its electronics will void the warranty.

To obtain warranty service, ship the unit postage prepaid to:

SPER SCIENTIFIC LTD.
8281 E. Evans Rd., Suite 103
Scottsdale, AZ 85260

The defective unit must be accompanied by a description of the problem and your return address. Register your product online at www.sperwarranty.com within 10 days of purchase.

Please note: The most current version of the manual can always be found at www.sperdirect.com