



**K1 145X**  
**4-UNIT REID VAPOR PRESSURE BATH**

***OPERATION AND INSTRUCTION MANUAL***

REV D

***Koehler Instrument Company, Inc.***

1595 Sycamore Avenue • Bohemia, New York 11716-1796 • USA

Toll Free: 1-800-878-9070 (US only) • Tel: +1 631 589 3800 • Fax: +1 631 589 3815

<http://www.koehlerinstrument.com> • e-mail: [info@koehlerinstrument.com](mailto:info@koehlerinstrument.com)

*Petroleum Testing & Analysis Instrumentation • Custom Design & Manufacturing*



---

# CERTIFICATE OF CONFORMANCE

---

## Reid Vapor Pressure Bath K1145X

---

This certificate verifies that part number K1145X, Reid Vapor Pressure Bath, was manufactured in conformance with the applicable standards set forth in this certification.

**Specifications:**

ASTM D323  
ASTM D1267  
IP 69  
IP 161  
ISO 3007  
ISO 4256  
DIN 51616  
DIN 51754  
FTM 791-1201  
NF M 07-007  
NF M 41-010

This unit is tested before it leaves the factory, to ensure total functionality and compliance to the above specifications and ASTM standards. Test and inspection records are on file for verification.



**Jesse Kelly**  
Application Engineer  
Koehler Instrument Company





## EC Declaration of conformity

Koehler Instrument Company, Inc.  
of 1595 Sycamore Av., Bohemia, New York USA

We declare that the product listed below meets all basic requirements in accordance with the following Directive(s) by design, type, and version placed upon the market by us.

2004/108/EC The Electromagnetic Compatibility Directive  
2006/42/EC The Machinery Directive by way of the Low-Voltage directive 2006/95/EC

**And hereby declare that:**

Equipment: *Reid Vapor Pressure Bath, 4-Unit*  
Model Number(s): *K11459*

### Qualifications:

This product may only to be used in a professional laboratory setting by authorized personnel following the instruction handbook.

**and**

This product declaration is valid for unmodified equipment when installed and operated by authorized personnel following the instruction handbook.

**Conforms to the following standards (as applicable):**

Safety	EN 61010-1:2010	Low-Voltage directive 2006/95/EC Safety Requirements for electrical equipment for measurement, control and laboratory use; by engineering design and risk review and by meeting the requirements of Hi-Pot Test (1500 VAC, 60 sec. per table 5) as detailed in the product's technical documentation.
EMC	EN 55011:2007	Meets the essential requirements of EMC Directive 2004/108/EC by engineering design review and by meeting the requirements of Conducted Emissions Test for Group 1 Class A as detailed in the product's technical documentation.

James R. Ball  
Dir. Research & Development

1595 Sycamore Av.  
Bohemia, NY 11716  
United States of America  
Dec 12, 2014



## **WEEE Directive Compliance Statement**

### **Background**

The goal of the WEEE Directive is to encourage design of environment-friendly products that increase reuse, recycling and other forms of recovery to reduce waste streams and applies to listed Electronic and Electrical Equipment (EEE) and Koehler's equipment falls broadly into Appendix 1A; Section 9 Monitoring and Control Equipment: Measuring, weighing or adjusting appliances for household or as laboratory equipment.

Any associated non-embedded equipment such as Lighting (Saybolt Color) and PCs/Printers also fall under WEEE. If provided with an order these ancillary items must be WEEE compliant. For these and other reasons (printer cartridges are regionalized) the equipment must be supplied through a third party supplier in Europe.

The WEEE Directive applies to electrical and electronic equipment falling under the categories set out in Annex IA provided that the equipment concerned is not part of another type of equipment that does not fall within the scope of this Directive. Annex IB contains a list of products which fall under the categories set out in Annex IA.

<http://eur-lex.europa.eu/LexUriServ/LexUriServ.do?uri=OJ:L:2003:037:0024:0038:en:PDF>

We do not qualify for any of the 10 exemption categories.  
<http://www.dpa-system.dk/en/WEEE/Products/Exemptions>

### **Professional use**

For equipment defined for 'professional use' local authorities have no role to play. Producers and importers are basically responsible for collection of WEEE recyclables from the professional user and for subsequent management. A separate statement is given cataloging the items that require separation from the equipment along with basic information on subsequent processing or recycling prior to disposal of the equipment.

<http://www.dpa-system.dk/en/WEEE/Products/Private-or-professional-use>

### **Responsibility for Registration and Annual Reporting:**

Koehler will not sell directly to end users in the EU and so has no responsibility to register within each EU state and to make annual reports. Koehler declares that this responsibility is born by the importer who is the first level of the distribution chain and is subject to producer responsibility. We will communicate this in writing to our distributor/importers in the EU stating they are responsible to satisfy WEEE registration and reporting requirements in the EU states where they conduct sales activities.

It is illegal to market electrical and electronic equipment covered by producer responsibility without being registered.

<http://www.dpa-system.dk/en/WEEE/Producers/Whoissubjecttoproducerresponsibility>

### **Product Design**

Koehler's designs allow for complete disassembly to a modular level which usually allows for standard recycling. A qualified refrigeration system technician must be consulted when disassembling and de-commissioning any equipment with refrigeration systems.

Koehler's scientific testing equipment is robustly designed to function over a long service life and are typically repaired many times over the course of years rather than being replaced. We believe that re-use and refurbishment is the very best form of re-cycling.

All batteries must be readily removable not soldered in place.

### **Recycling instructions**

In the event that replacement becomes necessary, we will include instructions, particularized to each instrument that informs the customer of their recycling responsibilities and giving them guidance in doing this. All Koehler equipment has been placed on the market since 13th August 2005 and so Koehler is defined as a "new WEEE producer". As such we must provide information on refurbishment, treatment, and re-use.

Our instrument manual will include this compliance statement and indicate that any collection of materials will be handled by their authorized distributor. In the event that the distributor is unreachable or is no longer a

distributor for Koehler Instrument, Co., other arrangements may be made including accepting the materials directly.

Recycling is free of charge. Shipping is the responsibility of the end users. Whether shipping to a distributor or to Koehler directly, safe, properly declared, and labeled packaging and shipping expenses are the sole responsibility of the end user.

### **WEEE Marking**



Since Koehler products are subject to the WEEE Directive we must display the WEEE symbol shown above in accordance with European Standard EN 50419 on the equipment. It must be indelible, at least 5mm in height, and clearly legible. If the equipment is too small the mark must be in the product literature, guarantee certificate, or on the packaging. Rules on marking are established in section 49 of the WEEE Order.

Koehler Instrument Company, Inc.  
c/o RECYCLING  
1595 Sycamore, Ave.  
Bohemia, NY 11716

As a minimum the following substances, preparations and components have to be removed from any separately collected WEEE:

- Mercury containing components, such as switches or backlighting lamps (compact fluorescent lamps, CFL),
- Batteries
- Printed circuit boards if the surface of the printed circuit board is greater than 10 square centimeters (about 4 sq in.),
- Toner cartridges, liquid and pasty, as well as color toner,
- Chlorofluorocarbons (CFC), hydrochlorofluorocarbons (HCFC) or hydrofluorocarbons (HFC), hydrocarbons (HC)
- Liquid crystal displays (together with their casing where appropriate) of a surface greater than 100 square centimeters and all those back-lighted with gas discharge lamps,
- External electric cables
- Components containing refractory ceramic fibers as described in Commission Directive 97/69/EC of 5 December 1997 adapting to technical progress Council Directive 67/548/EEC relating to the classification, packaging and labeling of dangerous substances (2),
- Electrolyte capacitors containing substances of concern (height > 25 mm, diameter > 25 mm or proportionately similar volume)

2. The following components of WEEE that is separately collected have to be treated as indicated:

- Equipment containing gases that are ozone depleting or have a global warming potential (GWP) above 15, such as those contained in foams and refrigeration circuits: the gases must be properly extracted and properly treated. Ozone-depleting gases must be treated in accordance with Regulation (EC) No 2037/2000 of the European Parliament and of the Council of 29 June 2000 on substances that deplete the ozone layer (4).



## Table of Contents

<b>1</b>	<b>Introduction .....</b>	<b>2</b>
1.1	<i>Koehler's Commitment to our Customers .....</i>	2
1.2	<i>Recommended Publications .....</i>	2
1.3	<i>Instrument Specifications .....</i>	3
<b>2</b>	<b>Safety Information and Warnings .....</b>	<b>3</b>
<b>3</b>	<b>Getting Started .....</b>	<b>3</b>
3.1	<i>Packing List.....</i>	3
3.2	<i>Unpacking .....</i>	3
3.3	<i>Assembly.....</i>	4
3.4	<i>Accessories for Test.....</i>	4
<b>4</b>	<b>Descriptions .....</b>	<b>5</b>
4.1	<i>Instrument Controls.....</i>	5
4.2	<i>Temperature Controller Operation .....</i>	6
<b>5</b>	<b>Operation .....</b>	<b>6</b>
5.1	<i>Bath.....</i>	7
5.2	<i>Power .....</i>	7
5.3	<i>Cylinders .....</i>	8
<b>6</b>	<b>Maintenance .....</b>	<b>8</b>
6.1	<i>Routine Maintenance .....</i>	8
6.2	<i>Replacement Parts.....</i>	8
<b>7</b>	<b>Wiring Diagrams.....</b>	<b>9</b>
7.1	<i>K11450 (115V Unit).....</i>	9
7.2	<i>K11459 (220V Unit).....</i>	10
<b>8</b>	<b>Service .....</b>	<b>11</b>
<b>9</b>	<b>Storage.....</b>	<b>11</b>
<b>10</b>	<b>Warranty.....</b>	<b>11</b>
<b>11</b>	<b>Returned Goods Policy.....</b>	<b>11</b>
	<b>Notes .....</b>	<b>12</b>

## 1 Introduction

The Koehler K1145X 4 Unit Reid Vapor Pressure Bath is the latest design for performing constant temperature Reid Vapor Pressure determinations of liquid petroleum products and liquefied petroleum gases (LPG).

This manual provides important information regarding safety, technical reference, installation requirements, operating condition specifications, user facility resource requirements, and operating instructions for the Reid Vapor Pressure apparatus. This manual should also be used in conjunction with applicable published laboratory procedures. Information on these procedures is given in section 1.2.

### 1.1 Koehler's Commitment to our Customers

Providing quality testing instrumentation and technical support services for research and testing laboratories has been our specialty for more than 50 years. At Koehler, the primary focus of our business is providing you with the full support of your laboratory testing needs. Our products are backed by our staff of technically knowledgeable, trained specialists who are experienced in both petroleum products testing and instrument service to better understand your requirements and provide you with the best solutions. You can depend on Koehler for a full range of accurate and reliable instrumentation as well as support for your laboratory testing programs. Please do not hesitate to contact us at any time with your inquiries about equipment, tests, or technical support.

**Toll Free: 1-800-878-9070 (US only)**

**Tel: +1 631 589 3800**

**Fax: +1 631 589 3815**

**Email: [info@koehlerinstrument.com](mailto:info@koehlerinstrument.com)**

**<http://www.koehlerinstrument.com>**

### 1.2 Recommended Publications

1. American Society for Testing and Materials (ASTM)  
100 Barr Harbor Drive  
West Conshohocken, Pennsylvania 19428-2959, USA  
Tel: +1 610 832 9500  
Fax: +1 610 832 9555

<http://www.astm.org>

email: [service@astm.org](mailto:service@astm.org)

#### ASTM Publication:

- ASTM D323: Vapor Pressure of Petroleum Products (Reid Method)
- ASTM D4693: Vapor Pressure of LP Gases

2. Energy Institute (IP)  
61 New Cavendish Street  
London, WIM 8AR, United Kingdom  
Tel: 44 (0)20 7467 7100  
Fax: 44 (0)20 7255 1472  
<http://www.energyinstpubs.org.uk/>

#### IP Publication:

- IP 69
- IP 161

3. International Organization for Standardization (ISO)  
1, rue de Varembe  
Case postale 56  
CH-1211 Geneva 20, Switzerland  
Tel: 41 22 749 01 11  
Fax: 41 22 733 34 30  
<http://www.iso.org>

#### ISO Publication:

- ISO 3007
- ISO 4256

4. Deutsche International Norm (DIN)  
<http://www.din.de>

#### DIN Publication:

- DIN 51616
- DIN 51754

5. Federal Test Method (FTM)

#### FTM Publication:

- FTM 791-1201

6. GPA

#### GPA Publication:

- GPA 2140

## 1.3 Instrument Specifications

**Models:** K11450  
K11459

### **Electrical**

**Requirements:** 115V 60Hz  
220-240V 50/60Hz

**Capacity:** Four (4) Vapor Pressure Apparatus, one-or two-opening type

### **Maximum**

**Temperature:** 212°F (100°C)

### **Temperature**

**Control Stability:**  $\pm 0.2^\circ\text{F}$  ( $\pm 0.1^\circ\text{C}$ )

**Bath Capacity:** 13.7 gal (51.9L) water

### **Dimensions**

**(l x w x h):** 15 x 15 x 36 in  
(38.1 x 38.1 x 91.5 cm)

**Net Weight:** 67 lbs (30.4 kg)

## 2 Safety Information and Warnings

**Safety Considerations.** The use of this equipment may involve *hazardous* materials and operations. This manual does not purport to address all of the safety problems associated with the use of this equipment. It is the responsibility of any user of this equipment to investigate, research, and establish appropriate safety and health practices and determine the applicability of regulatory limitations prior to use.

**Equipment Modifications and Replacement Parts.** Any modification or alteration of this equipment from that of factory specifications is not recommended voids the manufacturer warranty, product safety, performance specifications, and/or certifications whether specified or implied, and may result in personal injury and/or property loss. Replacement parts must be O.E.M. exact replacement equipment.

**Over Temperature Protection.** This unit is equipped with Over Temperature Protection (OTP) circuitry to prevent overheating. The unit will automatically interrupt power whether equipment malfunction or operator error causes the temperature to exceed either 20 °C above the set

point or the maximum recommended temperature range. The power can only then be restored by identifying and correcting the problem, allowing the unit to return to normal operating temperatures, and resetting the power to the unit.

**Unit Design.** This equipment is specifically designed for use in accordance with the applicable standard test methods listed in section 1.2 of this manual. The use of this equipment in accordance with any other test procedures, or for any other purpose, is not recommended and may be extremely hazardous.

**Chemical Reagents Information.** Chemicals and reagents used in performing the test may exhibit potential hazards. Any user must be familiarized with the possible dangers before use. We also recommend consulting the Material Data and Safety Sheet (MSDS) on each chemical reagent for additional information. MSDS information can be easily located on the internet at <http://siri.uvm.edu> or <http://www.sigma-aldrich.com>.

## 3 Getting Started

The instructions for preparing the equipment assume that the user is aware of the contents of this document, which lists the warranty conditions and important precautions.

### 3.1 Packing List

- K1145X 4-Unit Reid Vapor Pressure Bath
- K70519 RTD Temperature Probe Assembly
- K1145X-Manual 4-Unit Reid Vapor Pressure Bath Operation and Instruction Manual

Accessories (purchased separately, see Section 3.4 for more information):

- K11500 Reid Vapor Pressure Cylinder, One-Opening Type
- K11201 Reid Vapor Pressure Cylinder, Two-Opening Type
- 311-Series Reid Vapor Pressure Gauges

### 3.2 Unpacking

1. Carefully remove the wooden crate from around the unit and place the bath on a firm level surface free from excessive drafts, where there are no corrosive fumes, excessive

moisture, high room temperature, or excessive dust.



**WARNING:** Be sure two or more individuals are available for extracting and lifting instrument from box to cart and from cart to bench. Individuals must lift in accordance to proper technique. See Figure below.

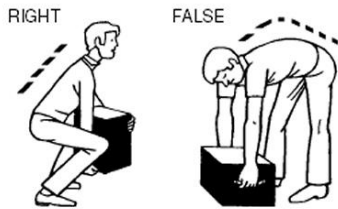

2. Lift instrument from cart and place on bench.
3. Ensure that all parts listed on the packing list are present. Inspect the unit and all accessories for damage. If any damage is found, keep all packing materials and immediately report the damage to the carrier. We will assist you with your claim, if requested. When submitting a claim for shipping damage, request that the carrier inspect the shipping container and equipment. Do not return goods to Koehler without written authorization.

### 3.3 Assembly



**WARNING:** Do NOT power on the bath without filling with water. See Section 5.1.

**Equipment Placement:** Place the instrument on a firm, level table in an area with adequate ventilation or in a hood. The unit may be leveled by making minor turning adjustments to the feet located at the base of the unit. Please note that Koehler does not supply a level with this equipment.

**Environmental Conditions:** The instrument environment must comply with the following conditions for proper setup:

- No / Low Dust
- No direct sunlight
- Not near heating or AC ventilation ducts
- No Vibrations

- Clearance from other instruments
- Temperature Range: 5 to 40°C
- Elevation to 2000 meters
- Relative Humidity: < 80%

**Temperature Probe:** The RTD Thermocouple probe is shipped in a separate bag within the bath. Remove the thermocouple from the bag and insert it in the thermocouple port. Insert the RTD connector into the receptacle located on the rear of the bath (see Section 4.1)

### 3.4 Accessories for Test

#### Reid Vapor Pressure Cylinders



Koehler offers both one-opening and two-opening type Reid Vapor Pressure Cylinders for vapor pressure tests of liquid petroleum products, volatile crude oil, and liquefied petroleum gas (LPG). The cylinders consists of upper and lower chambers in the required 4:1 volume ratio, and O-ring gaskets provide tight seal between chambers and at

gauge coupling. One-opening type is for gasoline and other products having a Reid Vapor Pressure below 26psa. Two opening type is for liquid products having a Reid Vapor Pressure above 26 psi and for LPG. For LPG testing, the two-opening type apparatus is used with an additional bleeder valve assembly.

Part No.	Description
K11500	Reid Vapor Pressure Cylinder, One-Opening Type
K11201	Reid Vapor Pressure Cylinder, Two-Opening Type
K11202	Bleeder Valve Assembly for LPG tests (for K11201 Cylinder)

### Reid Vapor Pressure Gauges

Part No.	Range psi/kPa	Figure Intervals psi/kPa	Interval Graduations psi/kPa
311-005-002	0-5	0.5psi	0.05 psi
311-015-002	0-15/0-100	1.0/10	0.1/1.0
311-030-002	0-30/0-200	5.0/20	0.5/2.0
311-060-002	0-60/400	5.0/50	0.2/2.5
311-100-002	0-100/700	10/50	0.5/2.5
311-250-001	0-250/1750	25/100	1.0/20
311-600-003	0-600/4200	50/250	2.0/25

### Additional Accessories

Part No.	Description
250-000-18F	ASTM 18F Thermometer Range: 94 to 108°F
250-000-18C	ASTM 18C Thermometer Range: 34 to 42°C
250-000-65F	ASTM 65F Thermometer Range: 122 to 176°F
250-000-65C	ASTM 65C Thermometer Range: 50 to 80°C
K11810	Transfer Connection
371-000-002	Mercury Manometer
K112B-1-0-12	Manometer Adapter
AS568-210	O-ring Seal, between air and gas chambers
AS568-113	O-ring Seal, between gauge and bleeder valves
K40100	Flexible Tubing

## 4 Descriptions

### 4.1 Instrument Controls



- 1. Thermometer Port.** This port allows for independent temperature measurement of the bath temperature with a thermometer for precise temperature measurements and digital temperature controller calibration. If the controller needs to be calibrated, then please contact the Koehler technical service department.
- 2. Thermocouple Port.** This port allows for temperature measurement of the bath temperature with a Pt-100 RTD probe for precise temperature measurement.
- 3. Cylinder Hooks.** See section 5.3 for detail on placing cylinders in hooks.
- 4. Motor Switch.** Controls power to the motor for the stirrer.

5. **Temperature Controller.** The temperature controller regulates the bath temperature for the test procedure. Refer to Section 4.2 for full operational details.
6. **Power Switch.** This switch controls the power to the entire unit.

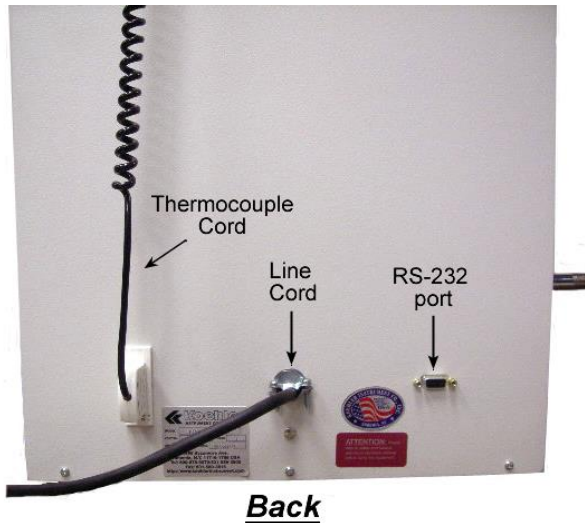

## 4.2 Temperature Controller Operation

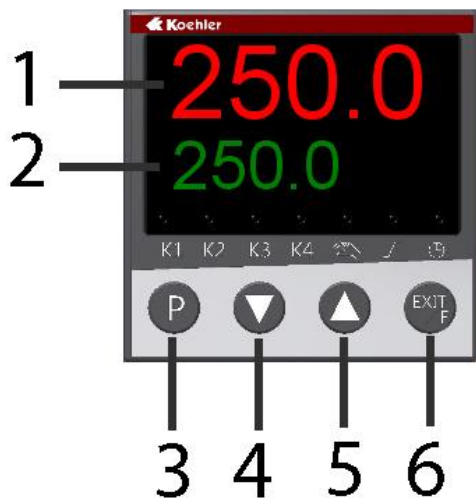

Figure 4. Temperature Controller

1. **Process Temperature Display.** The upper red LED display shows the process temperature as read from the RTD probe.
2. **Set Point Temperature Display.** The lower green LED display shows the set point temperature of the controller.

3. **Programming Key.** Permits scrolling through controller menu parameters. One Level Forward
4. **Down Key.** Used to decrease the set point temperature and to decrease or change parameter values when programming the temperature controller.
5. **Up Key.** Used to increase the set point temperature and to increase or change parameter values when programming the temperature controller.
6. **Exit / Function Key.** This key is used to exit or leave a level. One level backward

**IMPORTANT NOTE:** The digital temperature controller for the unit comes pre-programmed from the Koehler factory. Please do NOT attempt to re-program the digital temperature controller as this will void the product warranty. If assistance is required, please do not hesitate to contact the Koehler technical service department.

**Setting the Temperature.** Set the desired operating temperature by adjusting the set point with the up and down keys. The set point will be displayed in the lower green Set Point LED display and the actual temperature will be displayed in the upper red Process LED display. Please allow the instrument to fully equilibrate before proceeding with any testing.

**Temperature Calibration.** This routine allows the digital temperature controller to be calibrated to a certified thermometer.

- a. Use a certified calibrated measuring device to acquire the temperature. Calculate the difference between the measuring device and the Process value displayed on the controller.
- b. Press the program key two times until **Pct** is displayed in the lower green LED display. Press the DOWN key. CAL will display on the lower green display. If there is a value observed in the upper red LED display, add it to the calculated difference obtained in the previous step. This is the offset value.
- c. Press the Program Key. The lower green display will flash. Use the up or down keys



to adjust to the new calibration offset value on the upper red display calculated in the previous step. When the value has been entered, the controller will automatically store the value. The lower green display will stop flashing. If further adjustments are necessary, press the Program Key again. Resume regular operations by pressing the Exit / Function key two times. Verify if the new calibration is correct by observing the upper red display and comparing the value with the calibrated reference device.

**Auto Tune.** This routine allows the digital temperature control to learn the heating parameters needed for any particular set point temperature. This operation should be done when installing a new unit, after replacing or changing the bath medium type, or utilizing a different temperature set point 20% different from the previously used set point temperature.

- a. Set the operating temperature to the desired setting.
- b. Press the up and down arrow buttons simultaneously for about 5 seconds. When Auto Tune is active, the lower green LED display will blink **TUNE**. Auto Tune will automatically toggle off when the set point temperature is reached. Auto tune can be terminated by pressing the up & down buttons simultaneously again.

## 5 Operation

*For detailed preparation and operation instructions, refer to:*

<b>ASTM D323</b>	<b>DIN51616</b>
<b>ASTM D1267</b>	<b>DIN51754</b>
<b>IP69</b>	<b>FTM 791-1201</b>
<b>IP161</b>	<b>GPA 2140</b>
<b>ISO3009</b>	<b>ISO4256</b>

### 5.1 Bath

Fill the bath with water at room temperature. Be careful not to fill past the overflow valve.

 **WARNING:** MAKE SURE THE FLUID RELEASE VALVE ON THE DRAIN LOCATED IN THE BACK OF THE UNIT (SEE BELOW) IS CLOSED BEFORE FILLING WITH WATER.

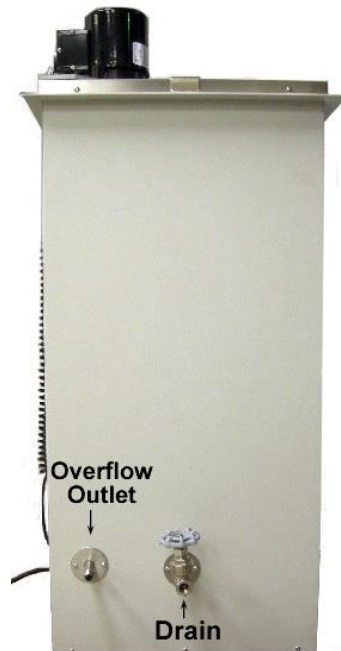

The overflow outlet will drain water if the liquid level reaches too high. This ensures the water does not overflow over the top of the bath.

### 5.2 Power

1. Connect the line cord to a properly fused and grounded receptacle with the correct voltage as indicated in section 1.3 or on the back of the unit.

 **WARNING:** Do **NOT** turn the power on unless the bath is filled with the proper medium; otherwise, damage may occur to the unit and the warranty would be void.

2. Power ON the unit by pushing the line switch.
3. Power ON the stirrer by pushing the motor switch.

### 5.3 Cylinders

#### Fully Assembled Cylinder (with Bleeder Valve)



1. RVP Gage
2. Gage Coupling
3. Bleeder Valve
4. Air Chamber
5. Transfer Valve
6. Liquid Chamber
7. Fill Valve

Attach the bleeder valve by removing the gage coupling from the top of the cylinder and screwing in the bleeder valve. Re-attach the gage coupling to the top of the bleeder valve, and screw in the gage. If the bleeder valve is not used, simply screw the gage into the coupling at the top of the cylinder.



#### Engaging Cylinders in the Bath

Place the assembled cylinder, including the gage, into the hooks in the bath as shown:



## 6 Maintenance



**WARNING.** Disconnect power to the unit before servicing to avoid exposure to high voltages and/or temperatures which may result in personal injury or death. If you have any questions about maintaining your equipment, then please do not hesitate to contact the Koehler technical service department.

### 6.1 Routine Maintenance

The K1145X 4-Unit Reid Vapor Pressure Bath requires little routine maintenance to provide many years of continuous service. However, over the course of time, some instrument parts may need to be replaced. When ordering replacement part(s), please provide the model number, serial number, and product shipment date of your equipment so that we can ensure you will receive the proper replacement part(s).

### 6.2 Replacement Parts

Part Number	Description
K11450-0-1	Heater, 2000W, 115V <sup>†</sup>
K11459-0-1	Heater, 2000W, 230V <sup>‡</sup>
K70519	RTD Temperature Probe Assembly
275-103-044	Temp. Controller, 100-240V 50/60Hz 7A
091-032-001	Solid State Relay, 20A, 4-32VDC
090-120-014	Relay, 120VAC, 10A, SPDT <sup>†</sup>
090-240-018	Relay, 240VAC, 10A, SPDT <sup>†</sup>
271-025-004	Circuit Breaker, 25A, 2 Pole <sup>†</sup>
271-015-004	Circuit Breaker, 2 Pole, 15A <sup>†</sup>
278-020-004	Time Delay Fuse, 20A, 600VAC
278-001-002	Fuse, 1A, Slo-Blo, 5x20mm
050-001-028	Switch, Single Pole, 15A
K23700-03013A	Motor, 115V 60Hz, 1/20HP <sup>†</sup>
K23700-03014A	Motor, 230V 60Hz, 1/15HP <sup>‡</sup>

<sup>†</sup>For 115V model ONLY (K11450)

<sup>‡</sup>For 230V model ONLY (K11459)



## 7 Wiring Diagrams

### 7.1 K11450 (115V Unit)

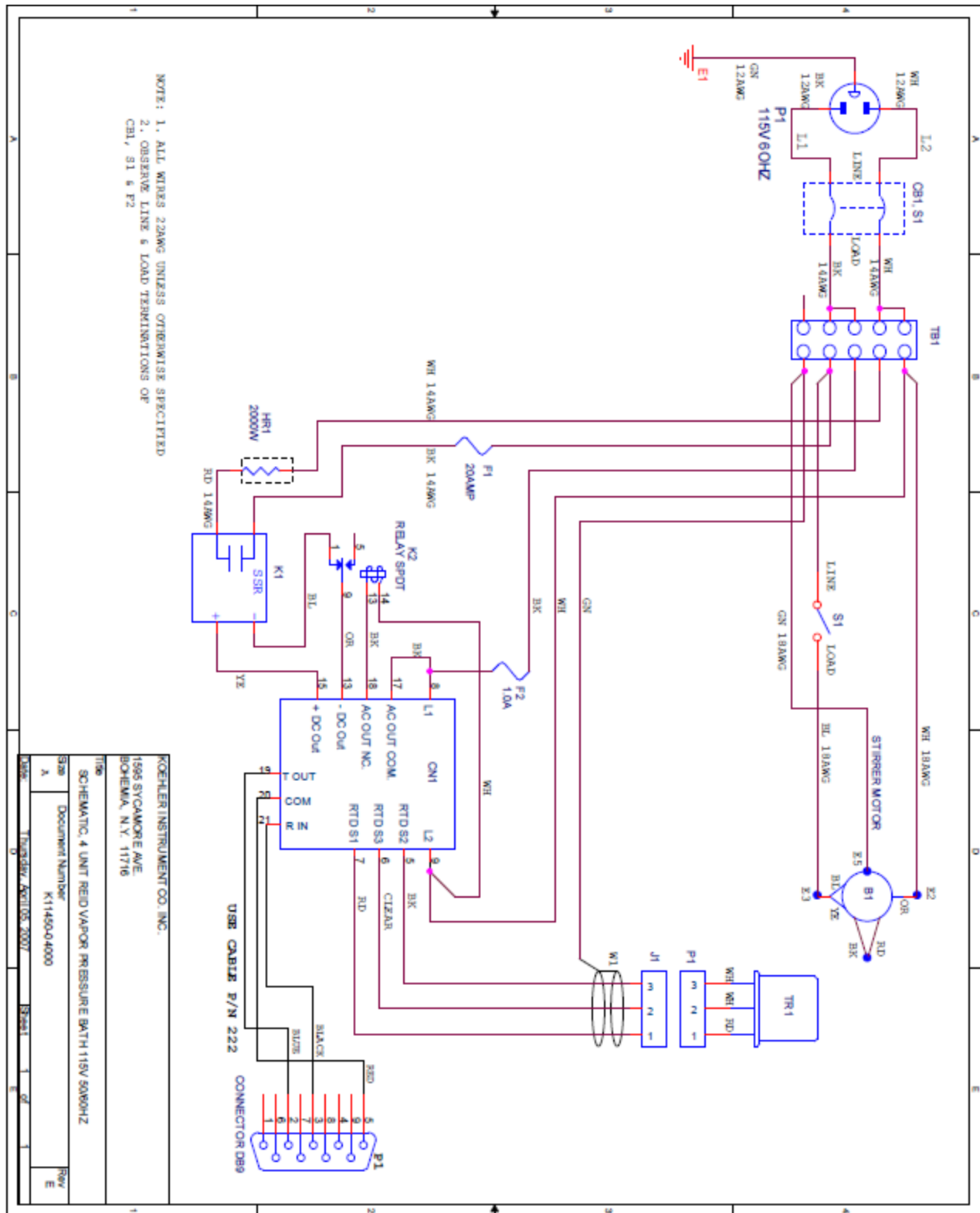

7.2 K11459 (220V Unit)

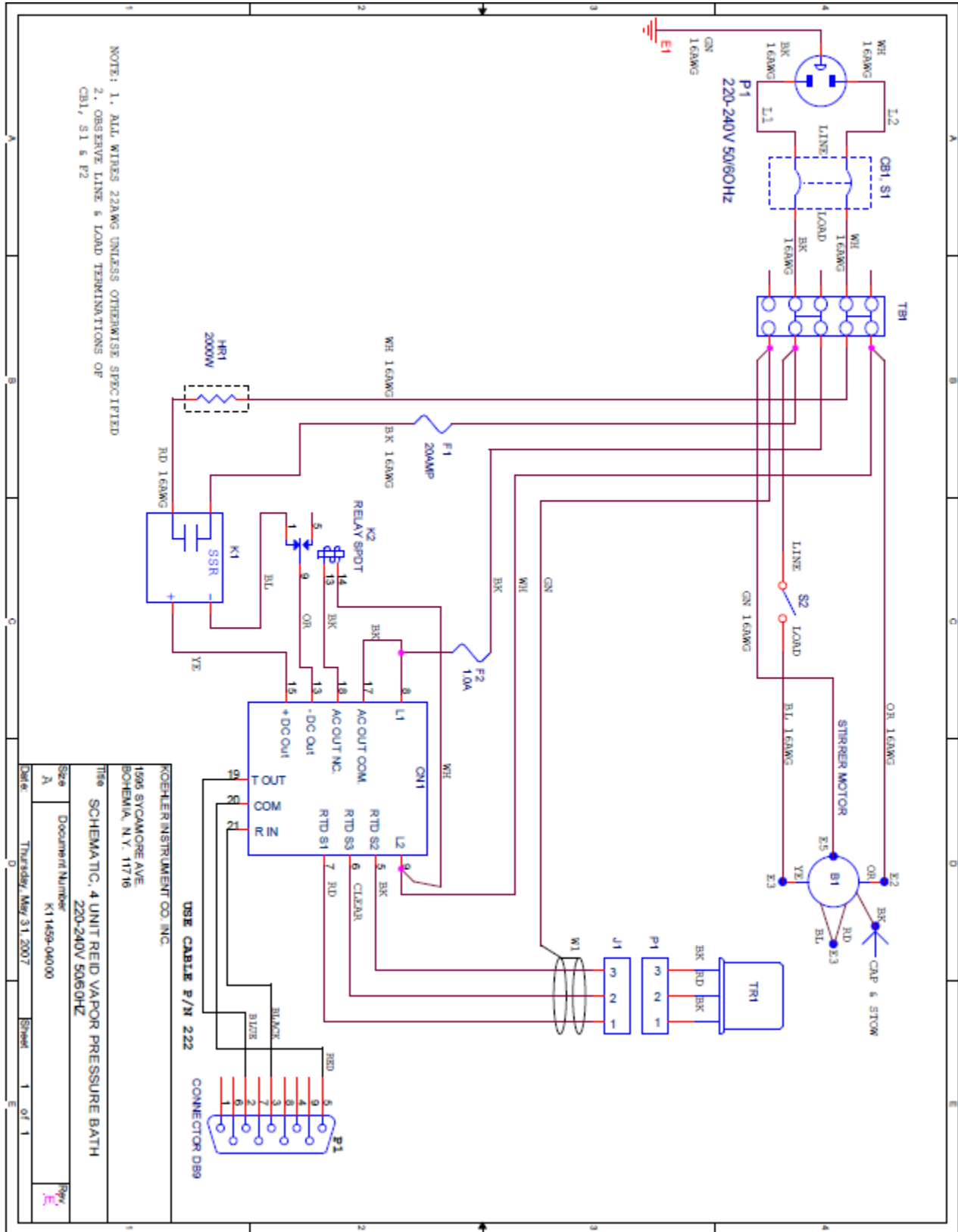

## 8 Service

Under normal operating conditions and with routine maintenance, the K1145X 4-Unit Reid Vapor Pressure Bath should not require service. Any service problem can be quickly resolved by contacting Koehler's technical service department either by letter, phone, fax, or email. In order to assure the fastest possible service, please provide us with the following information.

Model Number: \_\_\_\_\_

Serial Number: \_\_\_\_\_

Date of Shipment: \_\_\_\_\_

## 9 Storage

This laboratory test instrument is equipped with electrical components. Storage facilities should be consistent with an indoor laboratory environment. This testing equipment should not be subjected to extremes of temperature and/or moisture.

This equipment was shipped from the factory in a corrugated cardboard container. If long term storage is anticipated, re-packing the instrument in a water-resistant container is recommended to ensure equipment safety and longevity.

## 10 Warranty

We, at Koehler, would like to thank you for your equipment purchase, which is protected by the following warranty. If within one (1) year from the date of receipt, but no longer than fifteen (15) months from the date of shipment, Koehler equipment fails to perform properly because of defects in materials or workmanship, Koehler Instrument Company, Inc. will repair or, at its sole discretion, replace the equipment without charge F.O.B. its plant, provided the equipment has been properly installed, operated, and maintained. Koehler Instrument Company must be advised in writing of the malfunction and authorize the return of the product to the factory. The sole responsibility of Koehler Instrument Company and the purchaser's exclusive remedy for any claim arising out of the purchase of any product is the repair or replacement of the product. In no event shall the cost of the purchaser's remedy exceed the purchase price, nor shall Koehler Instrument Company be liable for any special, indirect, incidental, consequential, or exemplary damages. KOEHLER INSTRUMENT COMPANY, INC. DISCLAIMS ALL OTHER WARRANTIES,

EXPRESSED OR IMPLIED, INCLUDING ANY IMPLIED WARRANTIES OF FITNESS FOR A PARTICULAR PURPOSE. Please save the shipping carton in the event the equipment needs to be returned to the factory for warranty repair. If the carton is discarded, it will be the purchaser's responsibility to provide an appropriate shipping carton.

## 11 Returned Goods Policy

To return products for credit or replacement, please contact Koehler Customer Service with your purchase order number, our packing list/invoice number, the item(s) to be returned and the reason for the return. You will be issued a Returned Authorization (RA) number, which must be prominently displayed on the shipping container when you return the material to our plant. Shipping containers without an RA number prominently displayed will be returned to the sender. Goods must be returned freight prepaid. Returns will be subject to a restocking charge, the application of which will depend upon the circumstances necessitating the return. Some returns cannot be authorized, including certain products purchased from outside vendors for the convenience of the customer, products manufactured on special order, products shipped from the factory past ninety (90) days, and products which have been used or modified in such a way that they cannot be returned to stock for future sale.





