

USER-FRIENDLY INTERFACE

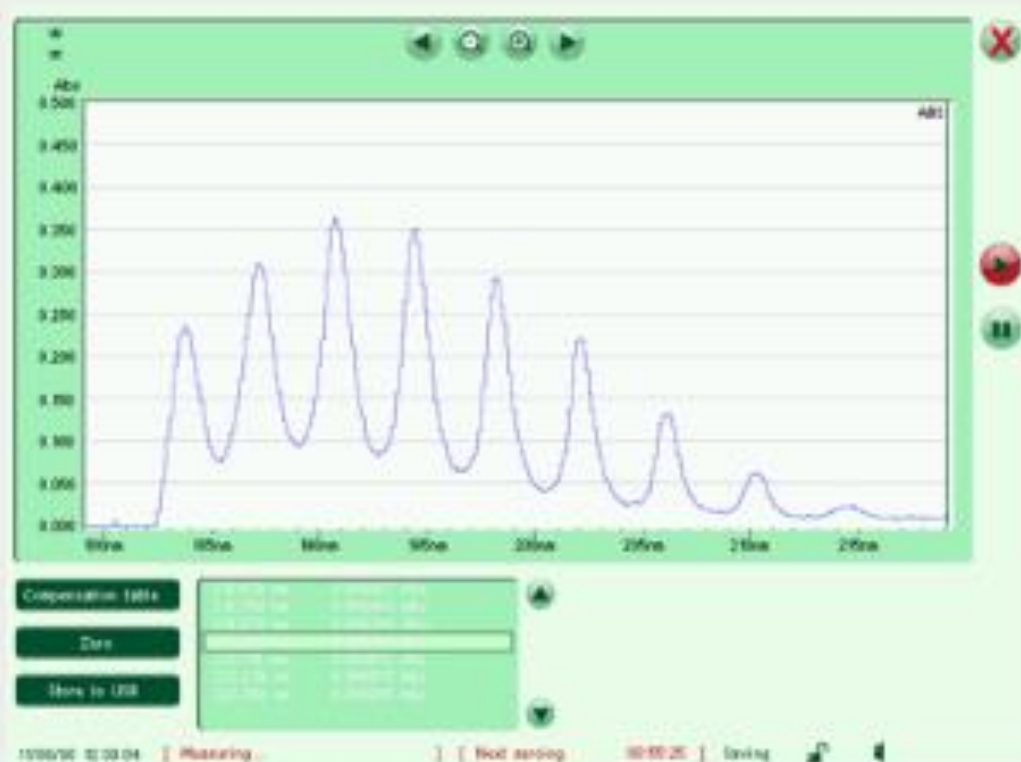

A colour touch screen display interface allows the user to easily navigate through a number of screens that are used to set and check all of the operating conditions of the instrument. A protective film limits the risk to damage the surface of the touch screen, especially against solvent and corrosive liquid.

COMMUNICATION

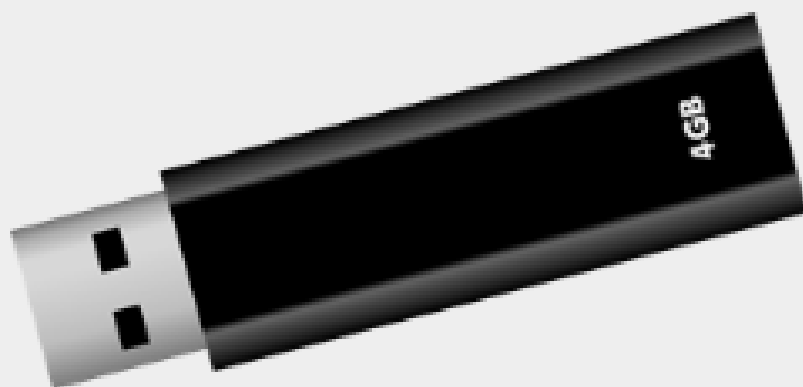

Recorded data and diagnostic files for each parameter can be downloaded to memory stick thanks to a USB port. This allows to collect easily these files on site without using a computer. The files are in text format and can be directly imported to Excel® for graphic charts.

NO INTERFERENCE WITH CO, CO2 AND CH4

The major emission gases like CO, CO₂, and CH₄ have no UV absorption, therefore they don't interfere with the measured gases. H₂O has a weak absorption in the UV range but at different wavelengths than combustion gases like NH₃, NO, NO₂ or SO₂. Consequently, H₂O, with an usual concentration between 5% and 20%, is not disturbing the measurements.

GAS CIRCUIT

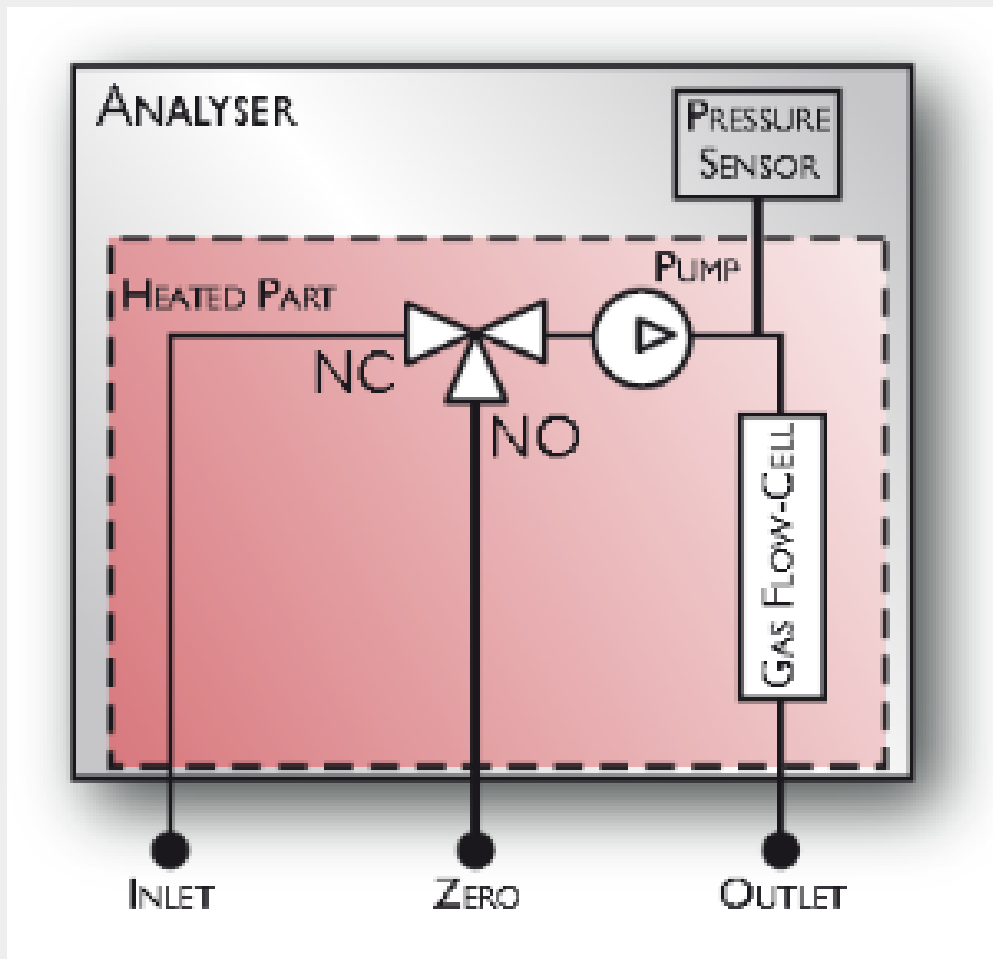

Three gas connections are available on the rear panel of the analyser :

- Inlet for the sample
- Zero air or nitrogen
- Outlet for sample or zero

Inlet and zero are connected on a 3 ways electric valve. When the automatic zero is activated, the solenoid valve switches the flow cell on zero air. A pressure sensor takes the pressure of measured gas to compensate it and to give a flow indication. All the gas circuit is in a heated compartment controlled within +/- 0.5 °C at an adjustable temperature between 40°C and 240°C. An optional pump may be included before the gas flow cell in order to pump the sample as well as the zero gas that may be ambient air for most of the applications.

LOW MAINTENANCE AND HIGH RELIABILITY

The design has been specially oriented for low maintenance and high reliability on the measurements. The UV xenon lamp is specified for a lifetime of 10^9 flashes. Therefore, the lifetime is about 3 year with continuous measurements or 10 years with one measurement per minute. This reduces considerably the maintenance and the risk of wrong measurement due to aged lamps or its replacement.

MULTI-GAS CONFIGURATION

Several gases can be measured in a same analyser if the sample gas composition is compatible with the selected algorithms and wavelengths. The analyser gives high measurement selectivity thanks to the recognition of the specific UV absorption spectrum of gases by using proprietary algorithms.

HEATED VERSION

The analyser is provided with an heating system for the gas circuit. The heating temperature can be adjusted up to 240°C. The high temperature evaporates any deposits on the windows.

AUTOMATIC COMPENSATION

An internal measurement of temperature and pressure of the sample is performed. A ratio related to the ideal gas law is applied on the measured value to compensate the effects of temperature and pressure

CEM500-L DIMENSIONAL DRAWING

